

EN



LK Armatur

News & Applications 2024





For the simpler, smarter everyday

LK

Simpler. Smarter. More sustainable. At LK, we believe there's a better way to do everything. That's why – from water, heating and hydronic solutions to pipe extrusion – we push for innovation over status quo and simplicity over complexity. It's a belief all of us at LK apply to every product and solution we create.

Our history

Founded in 1910, LK is a family business, working internationally in the heating, water and sanitation industry. A market leader in Sweden, the group currently employs approximately 400 people and actively increasing sales of products, systems and solutions in the Nordic region, Europe and the United States. LK works with continuous improvement and strives for a sustainable, long-term and respectful relationships with its employees, suppliers and customers.

Our companies

LK Armatur is a leader in Europe, producing millions of valves per year for the global HVAC market. Beyond individual products, we understand how all parts interact in your complete application. From standard to sophisticated customizations of valves, controllers, components and prefabricated units, our full-spectrum expertise makes it easy to get the results you need today, while anticipating your needs tomorrow.

LK Pex is a leading OEM manufacturer of high-quality plastic pipes for the HVAC industry, particularly housing applications. Our proprietary production technology for cross-linking PE-Xa tubes gives pipes unique flexibility and compressive strength. With this and every advancement we make, we aim to simplify your everyday challenges for smarter results today and tomorrow.

LK Systems is the leading manufacturer of easy-to-install systems for heating and tap water distribution in the Nordics. Through our prefabrication unit, we also provide tailor-made solutions that simplify the installation process even further.

For more information about the LK group, visit www.lk.nu.
For more information about LK Armatur, visit www.lkarmatur.com

LK Armatur - A One-Stop Supplier

LK Armatur was founded in 1985 when the LK Group increased its focus on supplying manufacturers of heaters and hot water heaters with valves and components.

We are a complete supplier of customised products and solutions and we produce millions of valves annually. We have advanced pipe manipulation & bending facilities for both stainless steel and copper pipes and our accessories come from leading suppliers in Europe. Our extensive product range consists of 4 product areas:

- Valves
- Electronic Heat Regulation
- Prefabrication
- Accessories



Helsingborg, Sweden; Our Main Office. We develop and manufacture most of our products here.

Bad Oeynhausen, Germany; Main Office for Germany sales company, LK Armatur Deutschland GmbH.

Zrenjanin, Serbia; Production unit focusing on pipe prefabrication.

Our aim is to provide high quality, technically advanced products that are easy to install and uncomplicated to use. We constantly develop and design new products and the demands are high to meet our customers' as well as our own high expectations.

We focus on customers who see energy saving and environmental awareness as a matter of course. The risk of energy shortage, the steady increase in energy prices and the problem of global warming have created a great need for cost and energy

efficient heating systems in which renewable energy sources can be utilized. The common denominator for our customers is their stringent requirements for quality, customization and delivery reliability.

Our management system complies with ISO 9001:2008 and ISO 14001:2004 for the development, manufacture and distribution of valves, electronic heating controls and prefabricated systems.





Pump Groups

LK HydronicGroup 90C.....	12
LK HydronicGroup C/C 90.....	13
LK HydronicGroup C/C 125.....	14

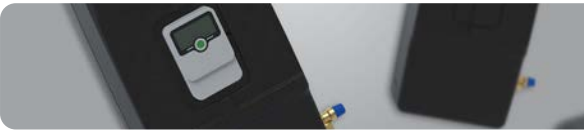

Tap Water Units

LK 250 TapWaterUnit.....	17
--------------------------	----



Solar Pump Units

LK 211 SolarStation.....	19
LK 211 SolarStation.....	20



Electric Portable Boilers

LK 450 EasyHeat P.....	22
LK 450 EasyHeat M.....	23



Valves for Water Heating

LK 551 HydroKit HWC.....	25
LK 551 HydroKit Solar.....	26
LK 551 HydroMix.....	27
LK 551 HydroMix F.....	28
LK 552 HydroMix.....	29



Zone Valves

LK 525 MultiZone 3W.....	34
LK 525 MultiZone 2W.....	35



Temperature Controllers

LK SmartComfort.....	37
----------------------	----



Other Products

LK 556 AntiFreeze.....	41
LK 322 CoolUnit.....	42
LK 360 NetMag.....	43



Company information

LK Group.....	3
LK Armatur.....	3
Applications.....	6
Curious about other products?.....	44
Follow us on social media.....	46

LK Armatur - Your Partner for Heating and Hot Water Solutions
 At LK Armatur, we're more than just a valve manufacturer; we're your partner in creating efficient heating and hot water solutions. With millions of valves produced annually, we understand how every component interacts in your unique applications. From standard products to custom solutions in Valves, Electronic Heat Regulation, Prefabrication, and Accessories, we're here to meet your specific needs. Our focus on energy efficiency and environmental responsibility helps you address the challenges of energy shortages and climate change. Choose LK Armatur for quality, customization, and reliability in every project.

Products for Water Heating



LK 514
MultiSafe



LK 548
AquaKit



LK 551
HydroMix



LK 535
ThermoFill®



LK 522
FilterBall



LK 523
VacuVent



LK 551 HWC
HydroKit



LK 551 Solar
HydroKit



LK 322
CoolUnit



LK 250 P
TapWater Unit



LK 865 C/C 125
HydronicGroup

Products for Heat Pumps



LK 514
MultiSafe



LK 548
AquaKit



LK 551
HydroMix



551 HWC
HydroKit



LK 525 3R
MultiZone



LK 840 2.0
ThermoMix®



LK 522
FilterBall



LK 556
AntiFreeze



LK 994
SafetyGroup



Expansion
tank



LK 905
Drain valve



LK 322
CoolUnit



LK 521
MultiFill®



Prefabricated
pipes,



LK Smart-
Comfort



LK 250 P
TapWater Unit



90 C
LK HydronicGroup



C/C 90
LK HydronicGroup



C/C 125
LK HydronicGroup





Products for Biofuel



 LK 514 MultiSafe	 LK 548 AquaKit	 LK 551 HydroMix	 LK 551 HWC HydroKit	 LK 525 3R MultiZone	 LK 840 2.0 ThermoMix®	 LK 820 ThermoVar®	 LK 823 ThermoVar®	 LK 519 ThermoSafe
 LK 522 FilterBall	 LK 160 SmartBio ©	 LK Smart- Comfort	 LK 810 2.0 ThermoMat	 LK 815 T Eco ThermoKit	 LK 816 E Eco ThermoKit	 LK 250 P TapWater Unit	 C/C 90 LK HydronicGroup	 C/C 125 LK HydronicGroup

Products for Underfloor Heating



 LK 419 ManifoldShunt	 LK 420 2.0 MiniShunt	 LK 421 2.0 Manifold Shunt	 LK 422 Tmax Manifold Shunt	 LK 423 RTC MiniLoop	 LK 430 Manifold	 LK 435 OptiFlow
 LK Smart- Comfort	 C/C 90 LK HydronicGroup	 C/C 125 LK HydronicGroup	 LK 440 EasyHeat	 LK 450 P EasyHeat	 LK 450 M EasyHeat	

Products for Solar Heating



 LK 514 MultiSafe	 LK 548 AquaKit	 LK 551 HydroMix	 LK 551 HWC HydroMix	 LK 552 HydroMix	 LK 551 HydroKit Solar	 LK 840 2.0 ThermoMix®	 LK 830 B ThermoMix®	 LK 821 ThermoVar®	 LK 525 3R, Solar MultiZone
 LK 321 Solar MultiFill®	 LK 522 FilterBall	 LK Smart- Comfort	 LK 150 SmartSol	 LK 994 SafetyGroup	 LK 211, 212 SolarStation	 LK 250 P TapWater Unit	 C/C 90 LK HydronicGroup	 C/C 125 LK HydronicGroup	

Products for District Heating

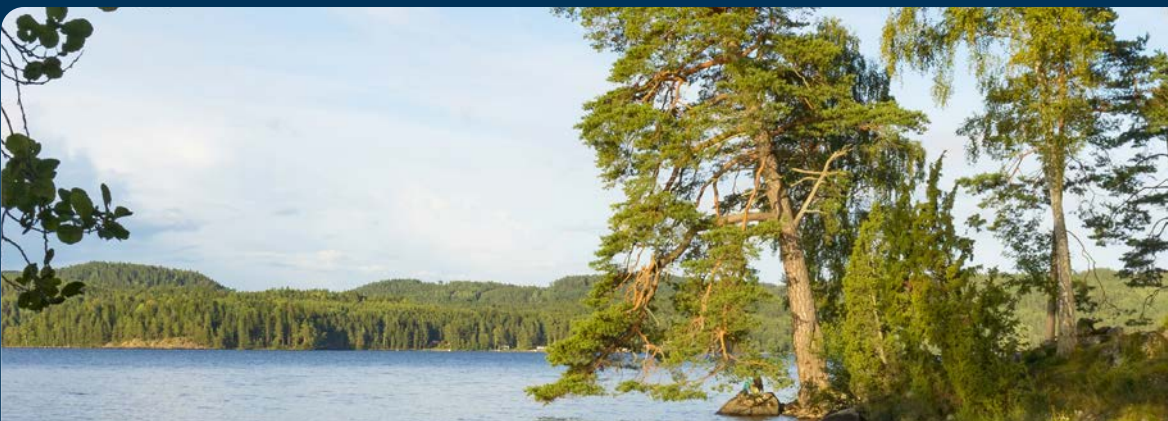

 LK 514 MultiSafe	 LK 548 AquaKit	 LK 551 HydroMix	 LK 551 HWC HydroMix	 LK 840 2.0 ThermoMix®	 LK 538 ThermoFill®	 LK 994 SafetyGroup
 LK 525 3R MultiZone	 LK Smart- Comfort	 LK 522 FilterBall	 Prefabricated pipes	 LK 250 P TapWater Unit	 C/C 90 LK HydronicGroup	 C/C 125 LK HydronicGroup

Pump Groups

The system is designed with an external 1½ connection for easy and quick installation on the boiler's flow and return lines

Ball valves with thermometer

Stable, two-piece insulation

Pump not covered by insulation - easy access

Easy to supplement with suitable electronic controller. In the event of a pump replacement, the mixing valve functions as a shut-off valve

Integrated check valve to prevent self-circulation, also serves as a gasket between ball valve and pipe

Efficient, versatile, and easy to install, **LK HydronicGroup C/C 125** is the answer to your heating needs. With a high-performance circulation pump, insulation, two ball valves with a thermometer, and a wall mounting bracket, it's a complete package for direct or mixed supply heating systems. The product you see pictured is our **LK 862 R** pump group, which includes a three-way mixing valve for mixed supply.

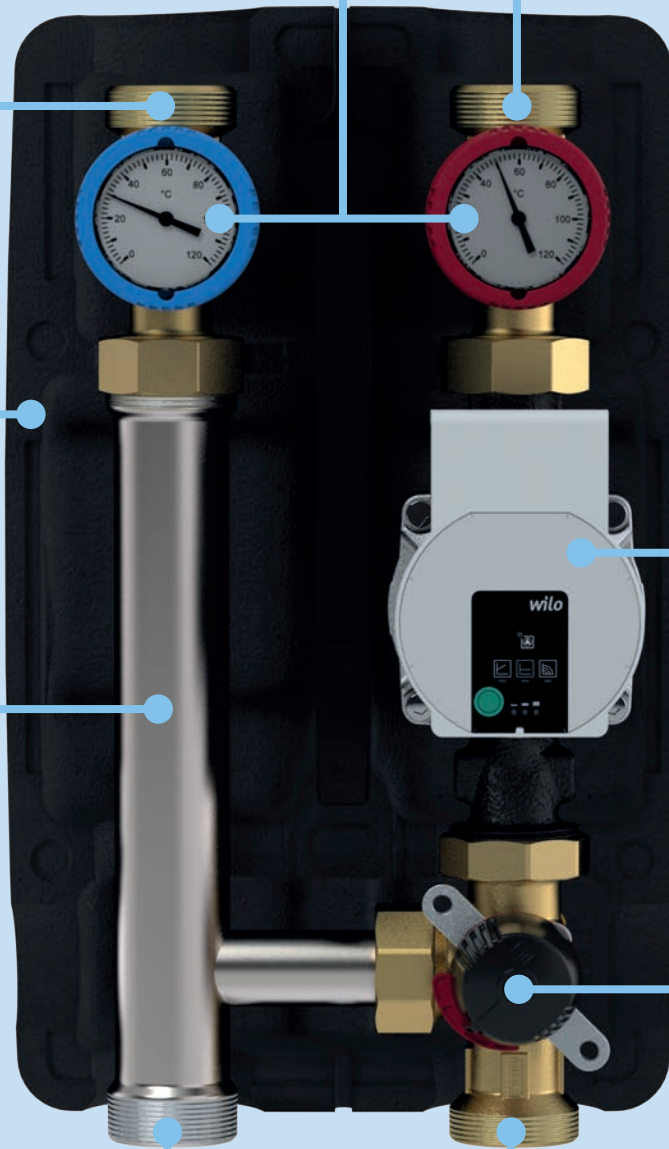



Underfloor Heating
LK 862

More than one heating system in your property?

Our pump group is available as various installations, depending on your needs.

If you've more than one heating system in your property, you can easily connect up to four different pump groups. Our pump groups can easily be placed individually and in a group of up to four units. With our electronic controller, SmartComfort, installed on the pump group, the system will be provided with the exact amount of heat required in the building at any given time. You can easily read the temperature on the integrated thermometers.

- All in one
- Easy to install
- Easy to combine with electronic regulation

Choose according to your needs:

LK 860 - MANIFOLD

LK 861 - DIRECT SUPPLY

LK 862 - MIXED SUPPLY

Three-way mixing valve is included.

LK 863 - MIXED SUPPLY

Thermic mixing valve, LK 551 HydroMix, is included.

LK 864 - LOADING UNIT

Thermic loading valve LK 823 ThermoVar® is included to ensure both an optimal temperature stratification in the accumulator tank and a high return temperature to the boiler, which increases the system's efficiency.

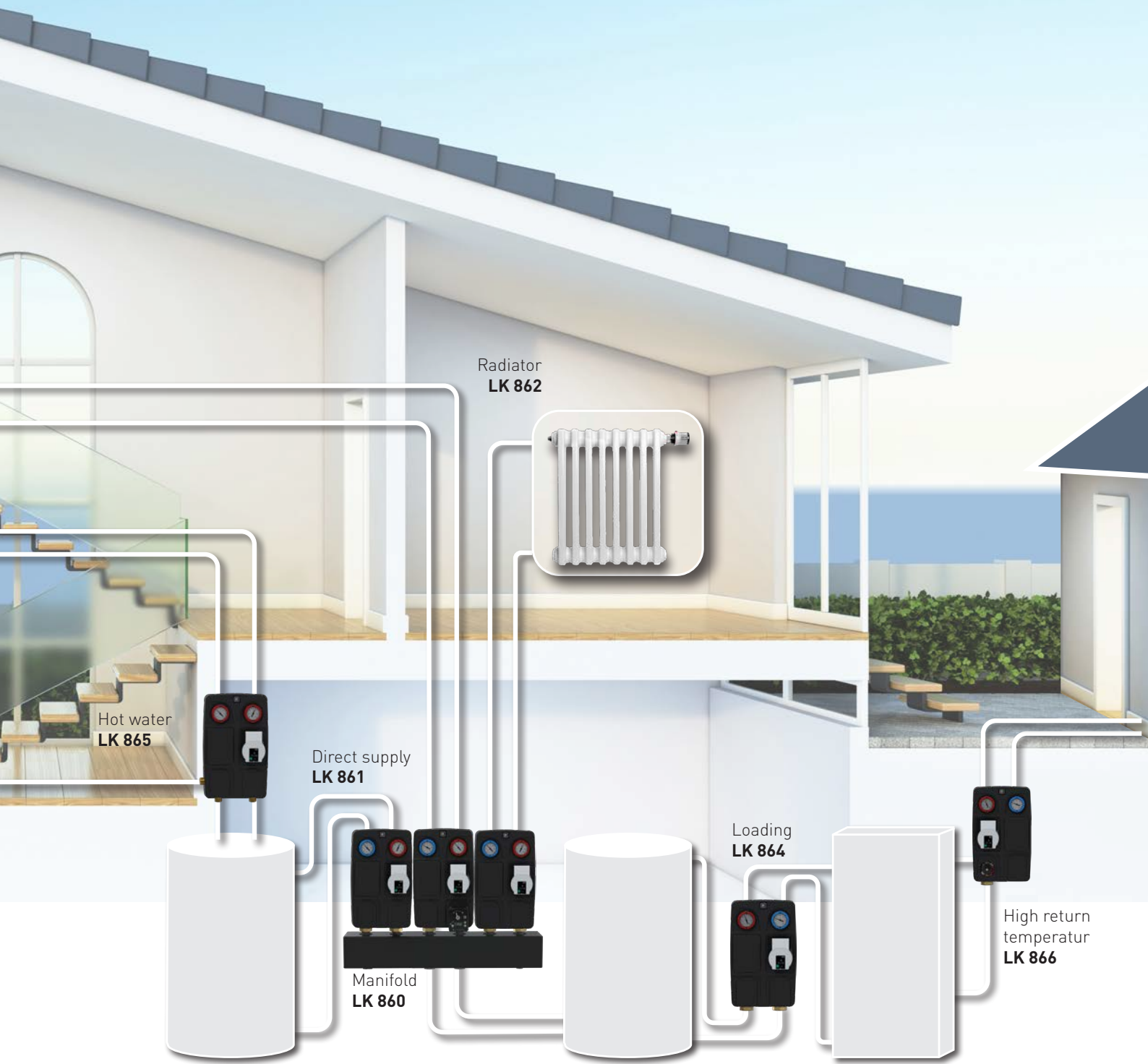

LK 865 - COMPLETE UNIT FOR HOT WATER CIRCULATION

Thermic mixing valve LK 551 HydroMix HWC is included.

LK 866 - HIGH RETURN TEMPERATUR

A four way mixing valve LK 841 ThermoMix® is included. Designed for heating systems where a high return temperature is required to prevent corrosion and thus extend the life length of the heat source.

LK 867 - FOR TWO HEATING UNITS

A bivalent mixing valve LK 830 ThermoMix® is included. Designed for heating systems, where energy is taken from two heating units connected in series or parallel or for storage tank systems where energy is extracted from two levels.



Pump groups

LK HydronicGroup 90C



- Adapted for cooling
- Easy to install
- Easy to combine with electronic regulation



TECHNICAL DATA

Voltage	230 VAC 50/60 Hz
Power consumption	10-75 W, depending on pump speed
Leakage	< 0,2% of Kvs at 100 kPa
Max. working pressure	1.0 MPa (10 bar)
Working temperature	Min. -15 °C Supply temperature: Min. 5 °C
Ambient temperature	Min. 5 °C/Max. 58 °C
Thread standard	Rp - female thread (F1"x M1")
Media	Water - Glycol mixture max. 50%
Circulating pump	Wilo Para 15-130/8-75/SC-9
Material, valve body	Brass EN 12165 CW617N
Cooling efficiency	7 kW (ΔT 10 °C 10 l/min.)

LK HydronicGroup is a complete pump group that is suitable for cooling systems where mixed supply is desirable.

LK HydronicGroup comprises a high efficient circulation pump, insulation, wall mounting bracket and two ball valves with thermometer. In the model where mixed supply is desired, a three-way mixing valve is included.

CAPACITY DIAGRAM

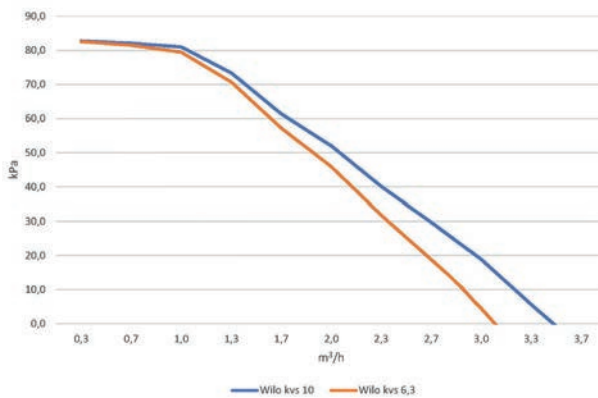

PUMP GROUP FOR PASSIVE COOLING

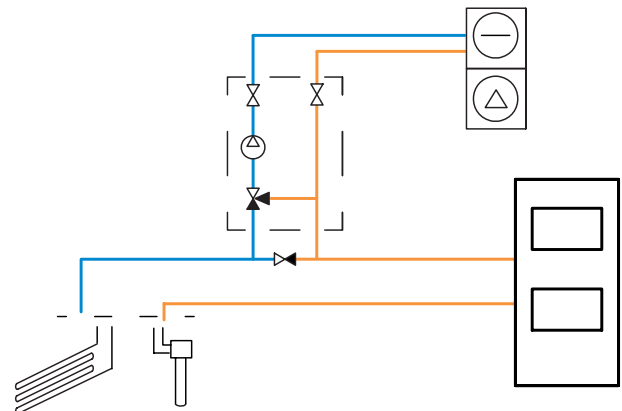

Pump groups

LK HydronicGroup C/C 90



- All in one
- Easy to install
- Easy to combine with electronic regulation



TECHNICAL DATA

Voltage	230 VAC 50/60 Hz
Power consumption	10-75 W, depending on pump speed
Leakage	< 0,2% of Kvs at 100 kPa
Max. working pressure	1.0 MPa (10 bar)
Working temperature	Min. 5 °C/Max. 100 °C
Ambient temperature	Min. 5 °C/Max. 58 °C
Thread standard	Rp - female thread, G - male thread (F1"x M1")
Media	Wilo: Water - Glycol mixture max. 50%
Media 2	Taco: Water - Glycol mixture max. 30%
Circulating pump	Wilo Para 15-130/8-75/SC-9, Taco ES2C 15-70-130
Material, valve body	Brass EN 12165 CW617N
Material, insulation	Expanded Polypropylene EPP

LK HydronicGroup is a complete pump group that is suitable for heating systems where direct supply or mixed supply is desirable.

LK HydronicGroup comprises a high efficient circulation pump, insulation, wall mounting bracket and two ball valves with thermometer. In the model where mixed supply is desired, a three-way mixing valve is included.

A manifold for two, optionally three, pump groups is available as an accessory, see accessories and spare parts. Wall mounting bracket is not included with manifold, it must be ordered separately, see accessories and spare parts.

LK 861 RIGHT

LK 861 LEFT

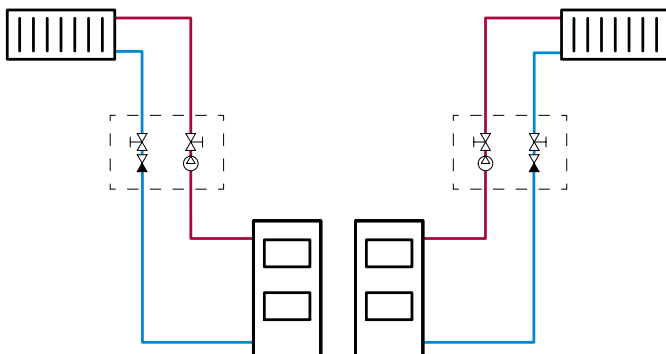
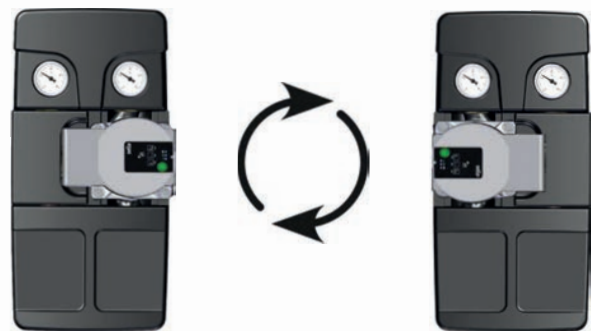

LK 861 - Pump group with direct supply

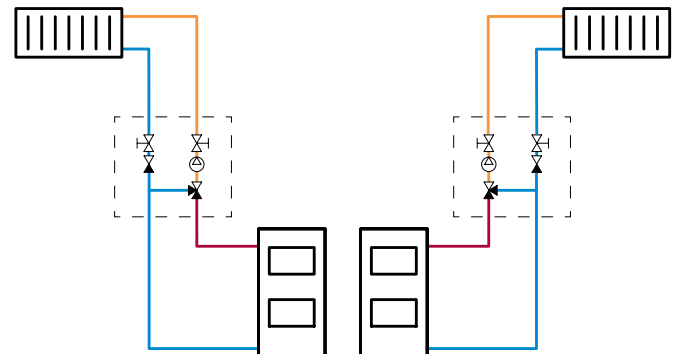

LK 862 - Pump group with mixing valve

Pump groups

LK HydronicGroup C/C 125



- All in one
- Easy to install
- Easy to combine with electronic regulation



TECHNICAL DATA

Voltage	230 VAC 50/60 Hz
Power consumption	10-75 W, depending on pump speed
Max. working pressure	1.0 MPa (10 bar)
Working temperature	Min. 5 °C/Max. 95 °C
Ambient temperature	Min. 5 °C/Max. 58 °C
Thread standard	Rp - female thread, G - male thread (M1½"/F1"x M1½")
Media	Water - Glycol mixture max. 50%
Circulating pump	Wilo Para 15-130/8-75/SC-9, Wilo Para 25-180/6-43/SC-12, Wilo Para 25-180/8-75/SC-12, Wilo PARA zKu 15-130/8 SC
Material, valve body	Brass EN 12165 CW617N
Material, insulation	Expanded Polypropylene EPP

LK HydronicGroup is a complete pump group that is suitable for heating where direct supply or mixed supply is desirable. Consists of a highly efficient circulation pump, insulation, wall mounting bracket and two ball valves with thermometer, on the return side there is an integrated check valve.

LK 860 manifold available with or without hydraulic separator for one, two, three optionally four pump groups. Wall mounting bracket are included with the manifold.

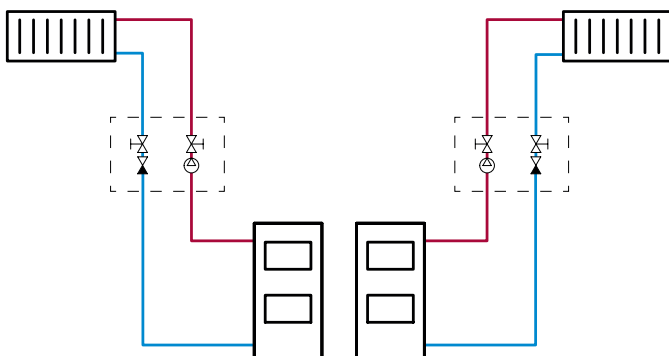

LK 861 - Pump group where direct supply is desired.

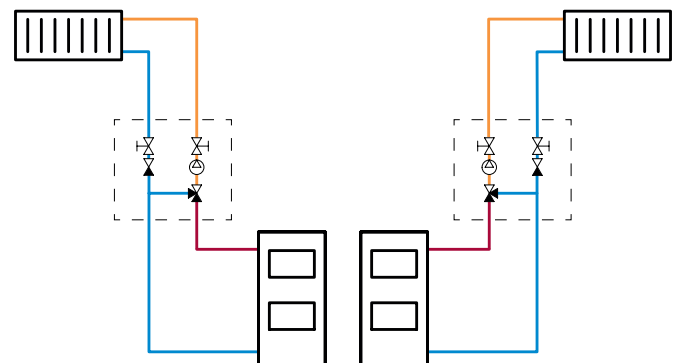

LK 862 - Pump group where mixed supply is desired, a three-way mixing valve is included.

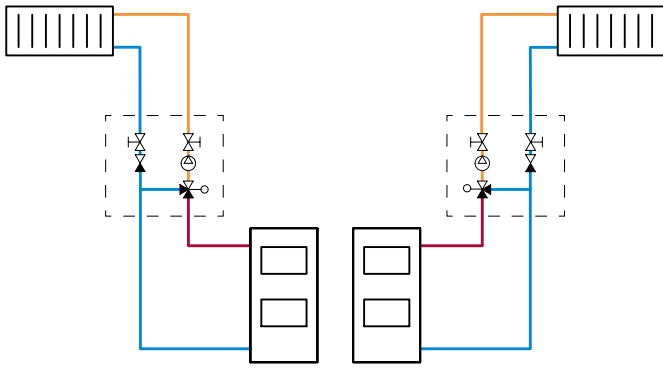

LK 863 - Pump group where mixed supply is desired, a thermic mixing valve is included. The LK 551 HydroMix has a thermostatic element that regulates the supply and return to achieve the desired supply temperature.

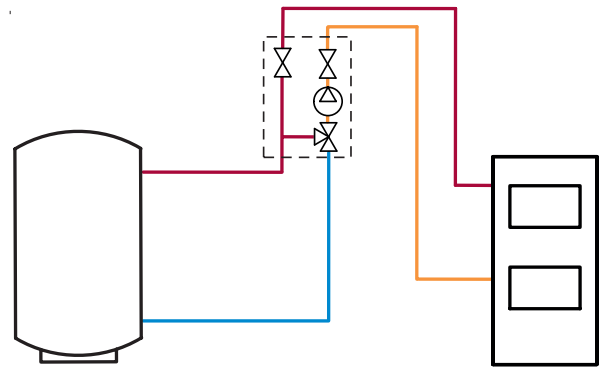

LK 864 - Pump group with a thermic loading valve LK 823 ThermoVar®. The pump group is intended to ensure both an optimal temperature stratification in the storage tank and high return temperature to the boiler, thus increasing the efficiency of the system.

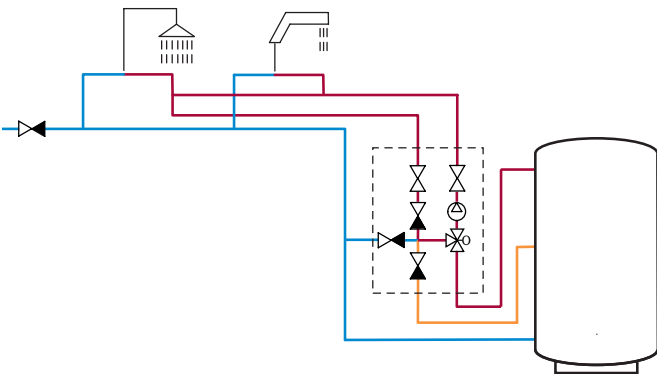

LK 865 - Complete unit for hot water circulation. Consists of a mixing valve, cross, circulation pump, insulation, connection kit and three check valves. The LK 551 HydroMix mixing valve has a thermostatic element that regulates the supply of both cold and hot water to the desired temperature. The valve has an anti-scald function that closes for incoming hot water if the cold water supply ceases.

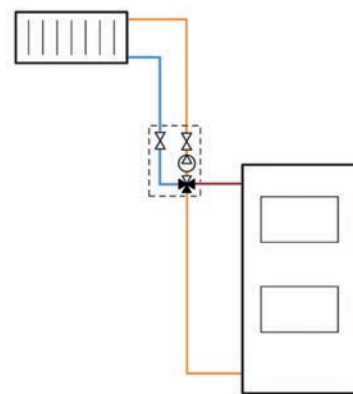

LK 866 - Pump group with a four way mixing valve, LK 841 Thermo-Mix®. The pumpgroup is designed for heating systems where a high return temperature is required to prevent corrosion and thus extend the life length of the heat source.

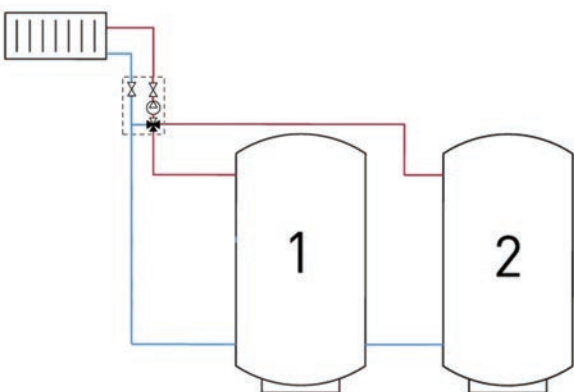

LK 867 - Pump group with a four way mixing valve, LK 830 Thermo-Mix® B. The pump group has a 4-way bivalent mixing valve that is designed for heating systems, where energy is taken from two heating units connected in series or parallel or for storage tank systems where energy is extracted from two levels. The pump group should be equipped with an automatic control unit to ensure that the most favourable heat source is prioritised at all times.

Tap Water Units

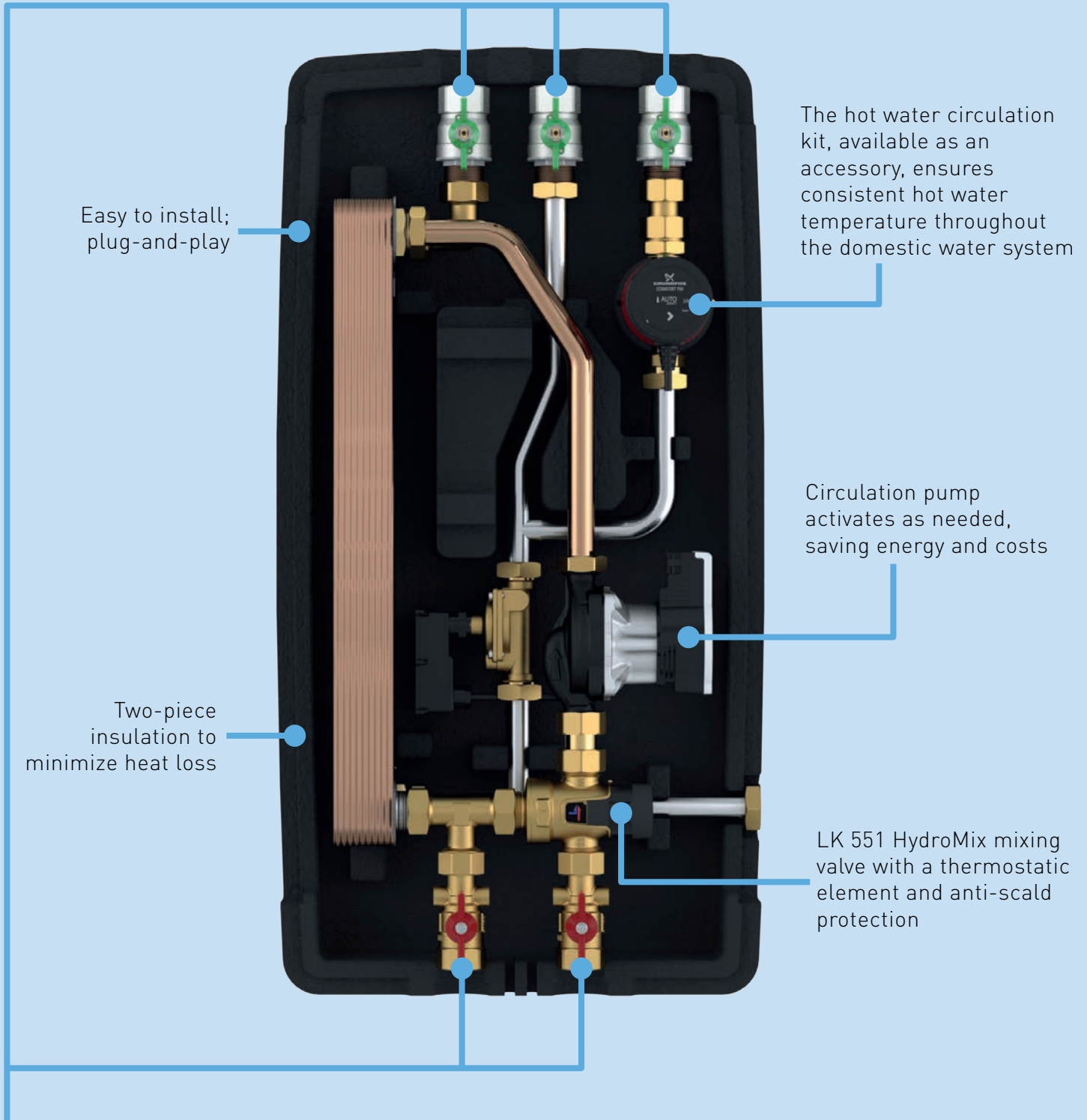

Valves with 1" internal threads

LK 250 TapWater Unit delivers hot water with precision. Whether you choose the electronic controller or the thermic mixing valve model, both options ensure reliable temperature control. The circulation pump is only active when hot water is required, which reduces energy consumption. A hot water circulation kit is available to maintain a consistent temperature throughout the house.

Tap Water Units

LK 250 TapWater Unit



- Easy to install - Plug-and-Play
- Scald protection with LK 551 HydroMix
- Available with anti-limestone coated heat exchanger.



TECHNICAL DATA

Voltage	230 VAC 50/60 Hz
Power consumption	10-75 W, depending on pump speed
Max. working pressure	1,0 MPa (10 bar)
Working temperature	Min. 5 °C/Max. 95 °C
Ambient temperature	Min. 5 °C/Max. 55 °C
Thread standard	G - female thread (F 1")
Media	Water - Glycol mixture max. 50%
Circulating pump	Wilo Para IPWM1 15-130/8 Wilo Para 15-130/8-75/SC-9
Material, insulation	Expanded Polypropylene EPP

The LK 250 TapWater Unit is a device for heating tap water.

LK 250 TapWater Unit P has an electronic controller unit that regulates the desired tap water temperature and at the same time regulates the inlet temperature to the plate heat exchanger to protect it from limestone.

The LK 250 TapWater Unit P consists of a plate heat exchanger, circulation pump, flow sensor, safety valve and an electronic controller.

The temperature of the tap water can be adjusted between 40 and 65 °C. The circulation pump only runs when hot water is required, which reduces energy consumption.

LK 250 TapWater Unit

Unlike the LK 250 TapWater Unit P, this unit has a thermal mixing valve which, instead of an electronic controller, regulates the tap water temperature and at the same time regulates the inlet temperature to the plate heat exchanger to protect it from limescale deposits.

The LK 250 TapWater Unit consists of a plate heat exchanger, circulation pump, flow sensor, safety valve and a mixing valve.

The temperature of the tap water can be adjusted between 35 and 65°C. The circulation pump only runs when tap water is needed, which reduces energy consumption.

When choosing a tap water unit, it is important to know the water quality in the area where the unit will be installed.

A hot water circulation kit is available as an accessory used to maintain the intended hot water temperature in the entire domestic hot water system, which is particularly suitable in buildings where a tap point is located some distance away.

LK 250 TAPWATER UNIT P - WITH CONTROLLER

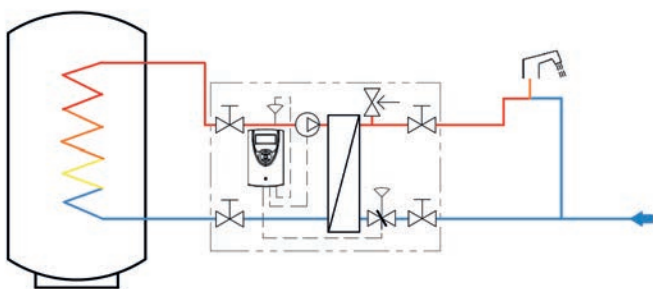

LK 250 TAPWATER UNIT - WITHOUT CONTROLLER

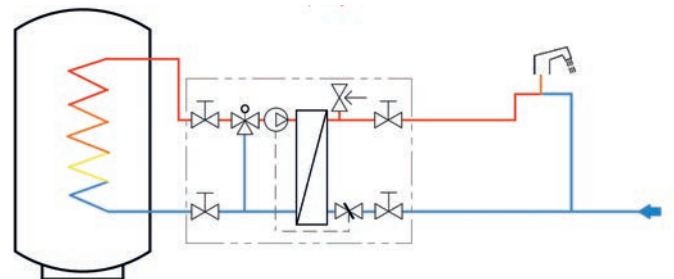

LK 250 TAPWATER UNIT P - WITH CONTROLLER AND HOT WATER CIRCULATION

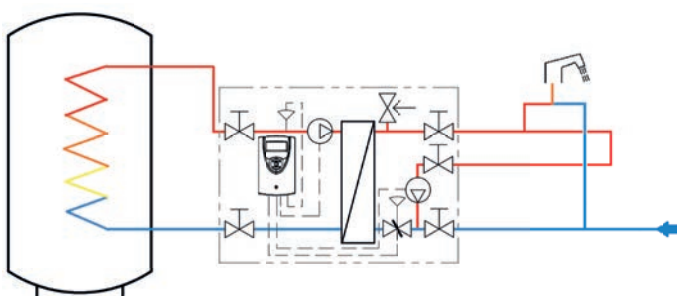

LK 250 TAPWATER UNIT - WITHOUT CONTROLLER WITH HOT WATER CIRCULATION

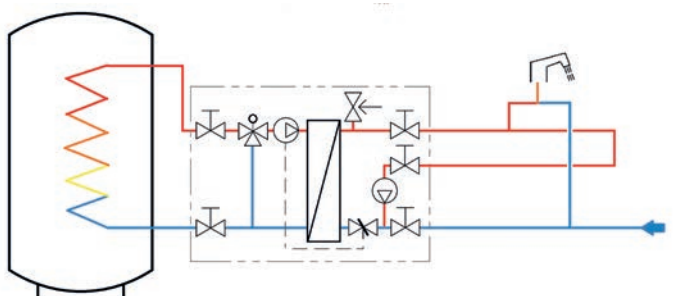

Solar Pump Units

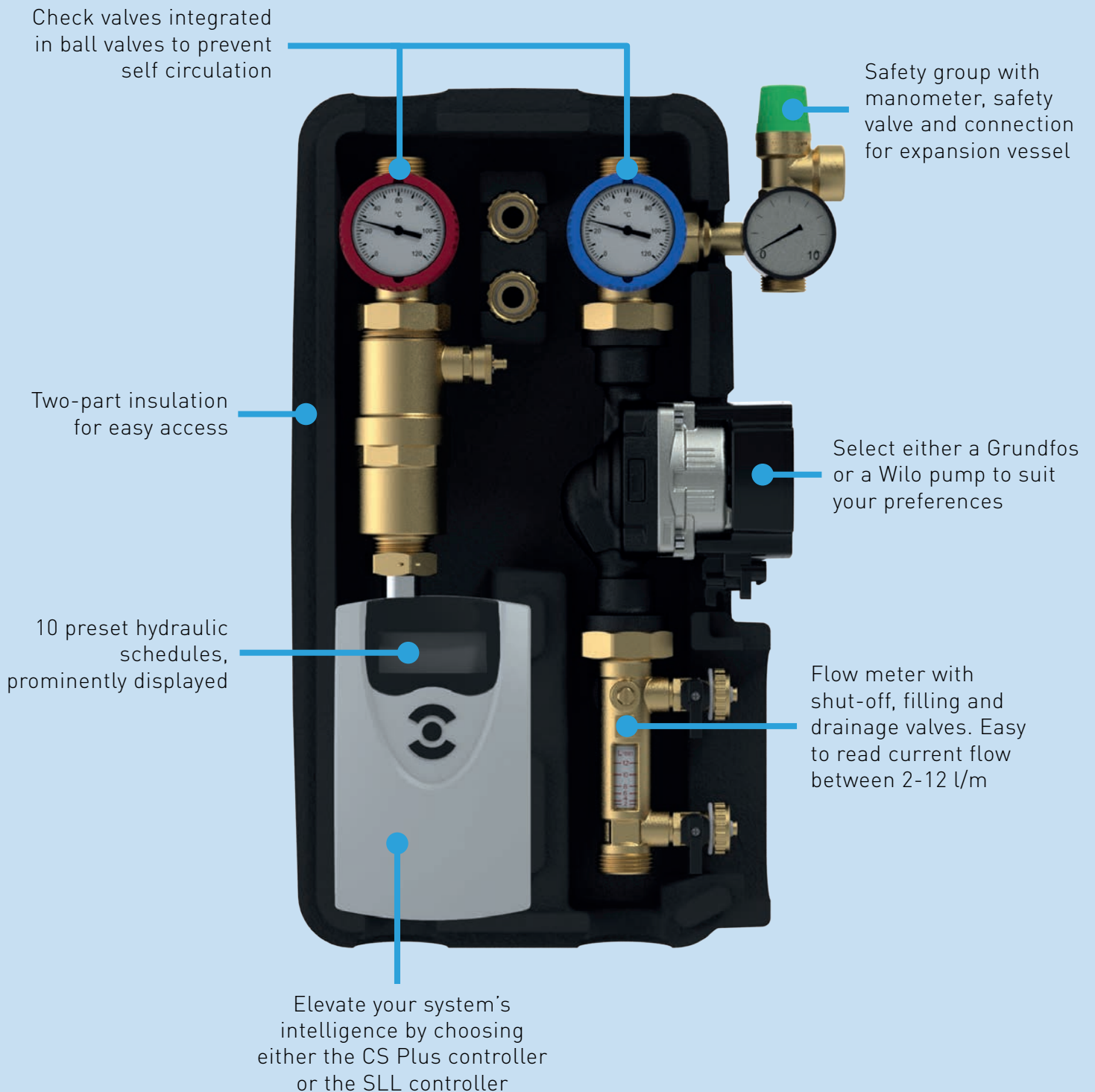

LK 212 SolarStation is your compact, dual-pipe solar pump unit, available with or without a controller. It's the complete package, equipped with all the essential components for ensuring the safe and efficient operation of your solar heating system.

Solar Pump Units

LK 211 SolarStation



- Compact single-pipe solar unit
- Reduced energy costs by using solar power
- Connections with 3/4" female thread and 1" male thread

TECHNICAL DATA

Voltage	230 VAC ± 10%, 50 Hz
Max. working pressure	1,0 MPa (10 bar)
Operating pressure	0,6 MPa (6 bar)
Working temperature	Max. 110 °C
Thread standard	G - male thread, G - female thread (F 3/4"/M 1")
Protection type	IP 20
Media	Water - Glycol mixture max. 50%
Sensors	PT 1000
Circulating pump	Grundfos UPM3 Solar 25-75 130 Wilo Para ST 25-130/8 IPWM2

LK 211 SolarStation is a compact single-pipe solar pump unit. It contains all the necessary components for a safe operation and control of the solar heating system such as safety group, circulating pump, ball valve with integrated check valve and thermometer, flow meter with shut-off, filling and drainage valves.

Option of selecting between two different controllers, LK 152 SmartSolar SLL or LK 152 SmartSolar CS Plus. A variant without a controller and/or circulation pump is also optional if you wish to supply it yourself.

LK 152 SmartSolar SLL and SC Plus has both 10 preset hydraulic schedules. The chosen hydraulic schedule and operating status is shown on the display.

LK 211 SOLARSTATION WITH LK 152 SMARTSOLAR SLL

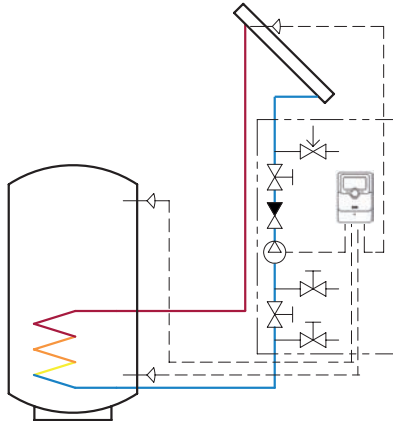

LK 211 SOLARSTATION WITH LK 152 SMARTSOLAR CS PLUS

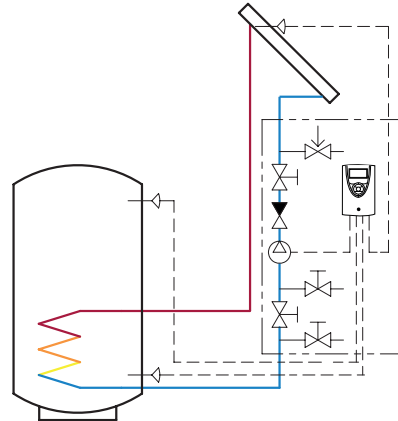

LK 211 SOLARSTATION WITHOUT CONTROLLER

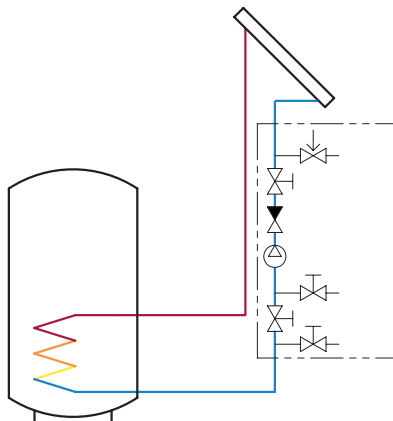

Solar Pump Units

LK 212 SolarStation



- Compact dual-pipe solar unit
- Reduced energy costs by using solar power
- Connections with 3/4" female thread and 1" male thread



TECHNICAL DATA

Voltage	230 VAC ± 10%, 50 Hz
Max. working pressure	1,0 MPa (10 bar)
Operating pressure	0,6 MPa (6 bar)
Working temperature	Supply: Max. 140 °C Return: Max. 110 °C
Thread standard	G - male thread, G - female thread (F 3/4"/M 1")
Protection type	IP 20
Media	Water - Glycol mixture max. 50%
Sensors	PT 1000
Circulating pump	Grundfos UPM3 Solar 25-75 180, Wilo Para ST 25-180/8 IPWM2

LK 212 SolarStation is a compact dual-pipe solar pump unit. It contains all the necessary components for a safe operation and control of the solar heating system such as safety group, circulating pump, ball valve with integrated check valve and thermometer, air separator with manual air vent, flow meter with shut-off, filling and drainage valves.

Option of selecting between two different controllers, LK 152 SmartSolar SLL or LK 152 SmartSolar CS Plus. A variant without a controller and/or circulation pump is also optional if you wish to supply it yourself.

LK 152 SmartSolar SLL and SC Plus has both 10 preset hydraulic schedules. The chosen hydraulic schedule and operating status is shown on the display.

LK 212 SOLARSTATION WITH LK 152 SMARTSOLAR SLL

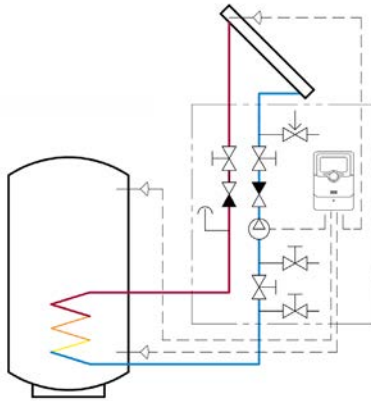

LK 212 SOLARSTATION WITH LK 152 SMARTSOLAR CS PLUS

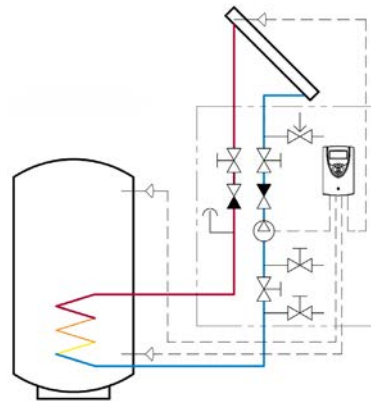

LK 212 SOLARSTATION WITHOUT CONTROLLER

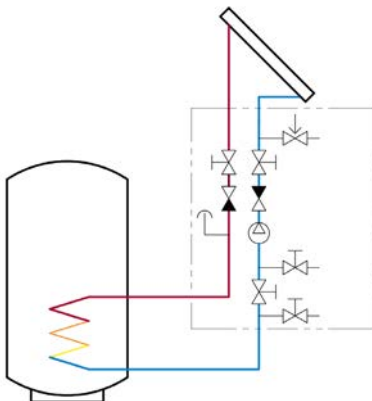

Electric Portable Boilers



Designed for temporary heating needs, this complete electric boiler is your solution for drying concrete slabs and heating construction sites. With programmable precision, constant temperature control, and a sturdy lockable cabinet, the **LK EasyHeat 450 P** is the reliable choice for your heating requirements.

Electric portable boiler

LK 450 EasyHeat P



- Portable
- Water level detection
- Lockable cabinet

TECHNICAL DATA

Voltage	400 V
Primary voltage, adapter	400 V
Max. boiler efficiency	9 kW (3 + 6 kW)
Sound level	<30 dB
Max. working pressure	3 bar
Working temperature	8-60 °C
Min. supply temperature	8 °C
Max. supply temperature	60 °C
Thread standard	G - female thread (F1")
Protection type	IP44
Media	Water - Glycol mixture max. 30%
Electrical connection	CEE-socket 400 V/16 A 5-pole
Circulating pump	Wilo Para 15/6 - Composite
Antifreeze function	Yes
Level guard	Yes
Expansion vessel	6 l
Overheating protection	80 °C
File import / export	Micro SD-card (not included)



The LK 450 EasyHeat P (programmable) 9 kW is a complete portable electrically heated boiler. It is primarily meant to be used as a temporary heater, e.g. for drying concrete slabs installed with under floor heating or for heating buildings under construction.

The temperature can be set between 8 and 60°C.

With the LK 450 EasyHeat P 9 kW, setting individual drying period programs is possible.

60 individual heating steps enable full control of the drying process and to receive a report on process afterwards if a micro SD-card is used.

When a program is finished, the boiler maintains a supply temperature of 8 °C to avoid risk of freezing.





With its built-in water level detection, damage to the immersion heater is prevented if the water level in the system gets too low.

A constant temperature can be set when used as a temporary electric boiler.

EasyHeat comes in a blue aluminum cabinet with inspection window, so you can monitor the unit during operation. The cabinet can be locked to prevent accidental changes to the set temperature.

The LK 321 MultiFill® is available as an accessory, and makes it easy to fill the system. The LK 522 filter ball is used to protect EasyHeat from dirt and magnetite. Transport trolley to simplify moving unit. Connection pipes for easy connection between EasyHeat and the heating system. Refer to Accessories & Spare parts.

SPARE PARTS AND ACCESSORIES

	Article no.	Article	Position
1. 	187354	Wilco Para 15/6 - Composite	1
2. 	187352	Transport trolley	2
3. 	187353	2 pcs. flexible hoses 1" F x 1" M, 1,5 m	3
4. 	092320	LK 321 MultiFill®	4
5. 	182437	LK 522 FilterBall Magnet	5

Electric portable boiler

LK 450 EasyHeat M



- Portable
- Water level detection
- Lockable cabinet

TECHNICAL DATA

Voltage	3 kW: 230 V 9 kW: 400 V
Primary voltage, adapter	3 kW: 230 V 9 kW: 400 V
Max. boiler efficiency	3 kW (1,5 + 1,5 kW) 9 kW (3 + 6 kW)
Sound level	<30 dB
Max. working pressure	3 bar
Working temperature	8-60 °C
Min. supply temperature	8 °C
Max. supply temperature	60 °C
Thread standard	G - female thread (F1")
Protection type	IP44
Media	Water - Glycol mixture max. 30%
Electrical connection	3 kW: CEE 16 A/230 V/50 Hz/1~ 1-Phase 9 kW: CEE-socket 400 V/16 A 5-pole
Circulating pump	Wilo Para 15/6 - Composite
Antifreeze function	Yes
Level guard	Yes
Expansion vessel	6 l
Overheating protection	80 °C



The LK 450 EasyHeat M (manual) 3 kW or 9 kW is a complete portable electrically heated boiler. It is primarily meant to be used as a temporary heater, e.g. for drying concrete slabs installed with underfloor heating or for heating buildings under construction.





With the LK 450 EasyHeat M, setting the required constant temperature between 8 and 60°C is easy.

The LK 450 EasyHeat is available in two versions: single phase 230 V with 3 kW output or 3-phase 400 V with 9 kW output. With its built-in water level detection, damage to the immersion heater is prevented if the water level in the system gets too low.

EasyHeat comes in a blue aluminum cabinet with inspection window, so you can monitor the unit during operation. The cabinet can be locked to prevent accidental changes to the set temperature.

The LK 321 MultiFill® is available as an accessory, and makes it easy to fill the system. The LK 522 filter ball is used to protect EasyHeat from dirt and magnetite. Transport trolley to simplify moving unit. Connection pipes for easy connection between EasyHeat and the heating system. Refer to Accessories & Spare parts.

SPARE PARTS AND ACCESSORIES

	Article no.	Article	Position
1. 	187354	Wilco Para 15/6 - Composite	1
2. 	187352	Transport trolley	2
3. 	187353	2 pcs. flexible hoses 1" F x 1" M, 1,5 m	3
4. 	092320	LK 321 MultiFill®	4
5. 	182437	LK 522 FilterBall Magnet	5

Valves for Water Heating

Compact design for versatile and hassle-free installation

Anti-scald function shuts off hot water if cold supply is interrupted

The thermostat-equipped mixing valve regulates hot and cold water to your desired temperature

Stable, two-piece insulation

Ideal for buildings with long water pipes, ensuring hot water reaches all areas quickly

Includes a mixing valve, cross, connection kit, and three check valves to prevent self circulation

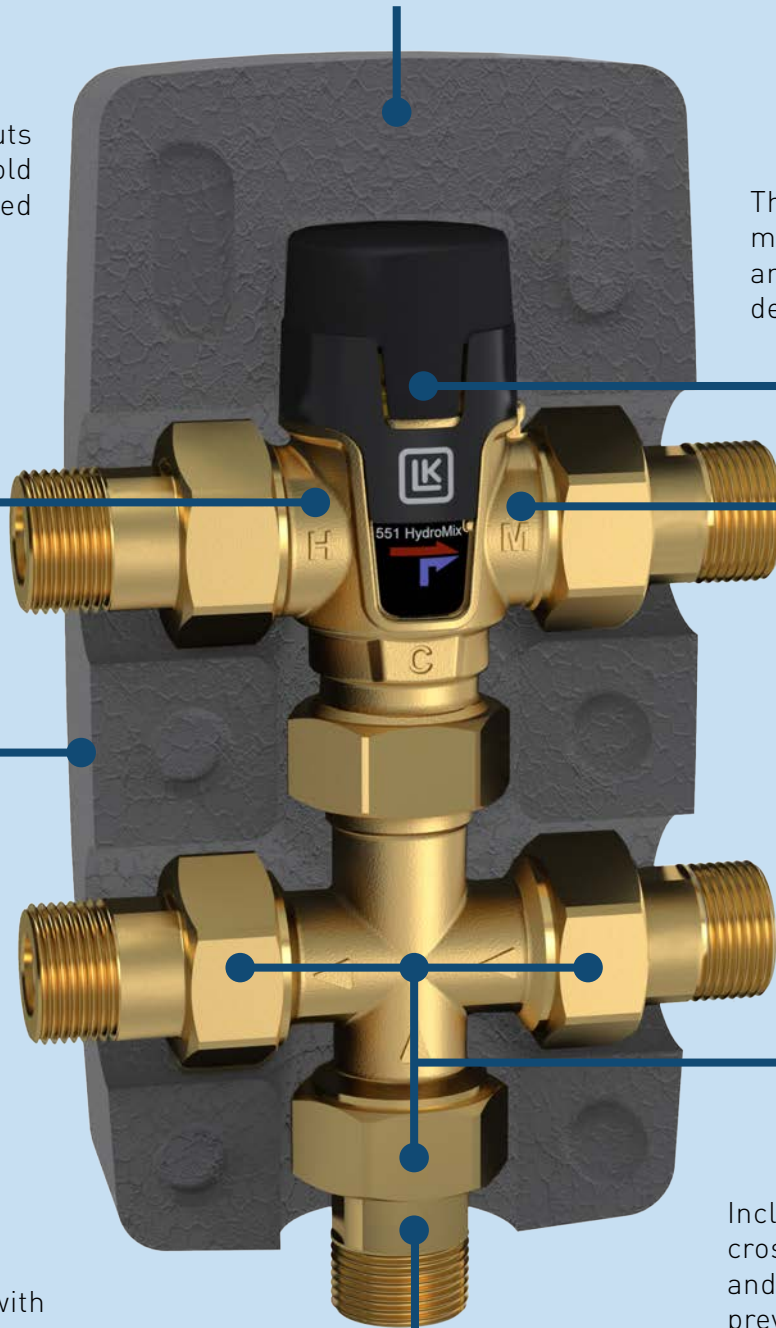

Experience instant hot water with **LK 551 HydroKit HWC**, even in buildings with lengthy water pipes. This compact unit includes a mixing valve, cross, connection kit, and three check valves for seamless hot water circulation. The thermostat-controlled mixing valve blends cold and hot water for an improved hot water experience, with added safety from the anti-scald feature.

Hot Water Circulation Unit

LK 551 HydroKit HWC



- Direct hot water
- Plug and play
- Scald protection

TECHNICAL DATA

Max. working pressure	1.0 MPa (10 bar)
Working temperature	Min. 5 °C/Max. 95 °C
Operating temperature	Min. 35 °C/Max. 65 °C
Thread standard	G - male thread (M 3/4")
Media	Water - Glycol mixture max. 50% Ethanol mixture max. 30%
Material, valve body	Brass EN 12165 CW617N, DZR Brass EN 12165 CW625N
Temperature stability	±3°C

LK 551 HydroKit HWC is a compact unit for hot water circulation. Hot water circulation offers instantly available hot water at a tap, so you don't have to wait on hot water. Hot water circulation is especially useful in buildings with long water pipes.

LK 551 HydroKit HWC consists of a mixing valve, cross, connection kit and 3 check valves, to prevent self circulation. The mixing valve has a thermostat that regulates the supply of both cold and hot water to the desired temperature. The valve has an anti-scald function that closes for incoming hot water in case the cold water supply ends.

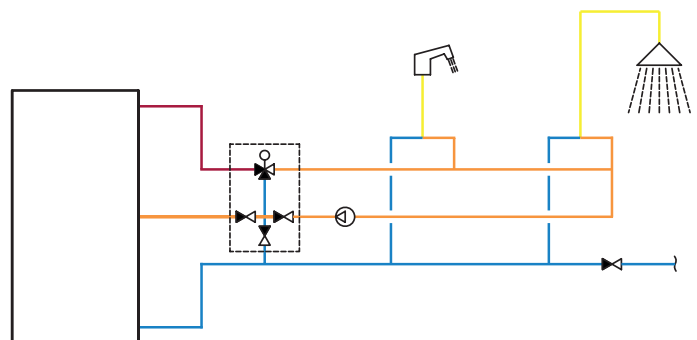
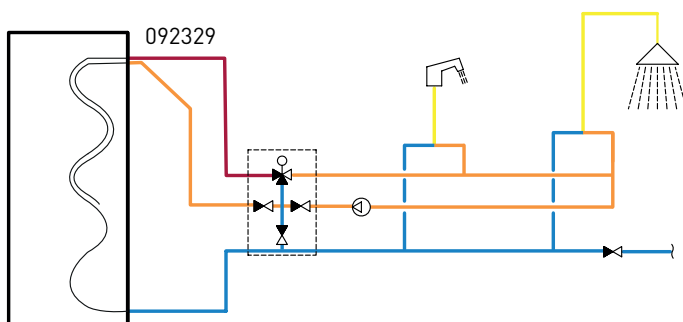

Valve Combination

LK 551 HydroKit Solar

- Simple installation
- Plug and play
- Scald protection



TECHNICAL DATA

Max. working pressure	1.0 MPa (10 bar)
Working temperature	Min. 5 °C/Max. 95 °C
Operating temperature	Min. 35 °C/Max. 65 °C
Divertingtemperature	Min. 42 °C/Max. 52 °C
Thread standard	G - male thread (M 3/4, M 1")
Media	Water - Glycol mixture max. 50% Ethanol mixture max. 30%
Material, valve body	Brass EN 12165 CW617N
Temperature stability	±3 °C

LK 551 HydroKit Solar is a valve combination, designed to energy optimize water heating from two different heat sources. In order to maintain the set water temperature, the warm water from one heat source is mixed and led directly to the mixed water outlet or if needed diverted to an other heat source for further heating.

LK 551 HydroKit Solar has two thermic valves; one diverting valve and one mixing valve with anti-scald function. The warm water temperature, for the mixing valve, is adjustable within the range of 35 °C to 65 °C and for the diverting valve the temperature is adjustable within the range of 42 °C to 52 °C.

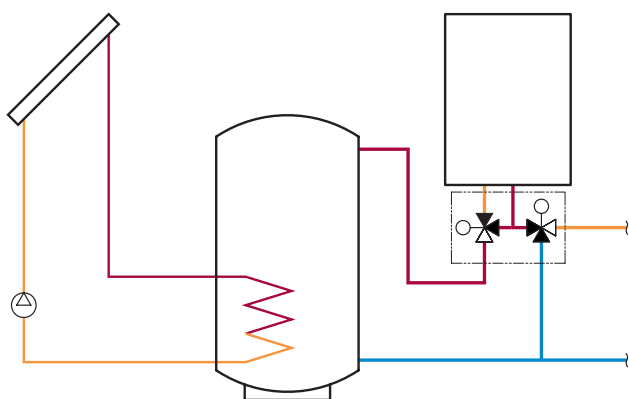

Thermic Mixing Valve

LK 551 HydroMix

- Anti-scald function
- Adjustable temperature



TECHNICAL DATA

Max. working pressure	1.0 MPa (10 bar)
Working temperature	Min. 5 °C/Max. 65 °C Min. 5 °C/Max. 95 °C
Operating temperature	Min. 10 °C/Max. 30 °C (Max. 65 °C) Min. 25 °C/Max. 45 °C Min. 35 °C/Max. 55 °C Min. 35 °C/Max. 65 °C
Thread standard	Rp - female thread, G - male thread (F 1/2"-1", M 1/2"-1 1/4", 15-28 mm)
Media	Water - Glycol mixture max. 50% Ethanol mixture max. 30%
Material, valve body	Brass EN 12165 CW617N, DZR Brass EN 12165 CW625N
Temperature stability	±3 °C

LK 551 HydroMix is an asymmetrical mixing valve for water heating and heating systems. The mixing valve has a thermostatic element that regulates the supply of cold as well as hot water in order to achieve the desired temperature. The valve has an anti-scald function that shuts off the incoming hot water flow in case of failure of cold water supply.

Arrows on the valve body indicate the direction of the flow.

C = incoming cold water

H = incoming hot water

M = outgoing mixed water

When fitted on top of boiler/storage tanks with built-in water heaters the valve should be installed with some space between boiler/storage tank and valve so as not to let the function of the valve be affected by heat radiation.

The valve knob is used to set the desired warm water temperature within the specified range. The protective cap prevents unintentional changes of the temperature setting.

The valve requires no maintenance but the installation should be checked regularly.

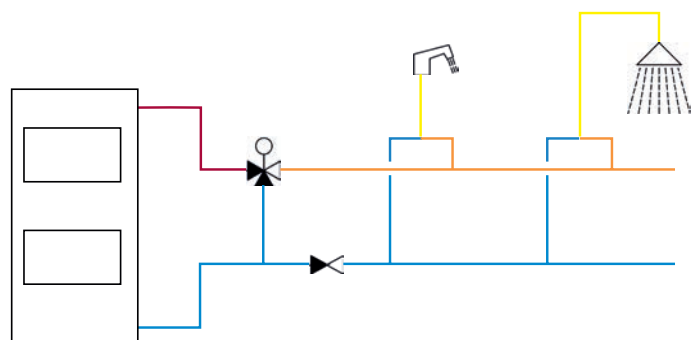
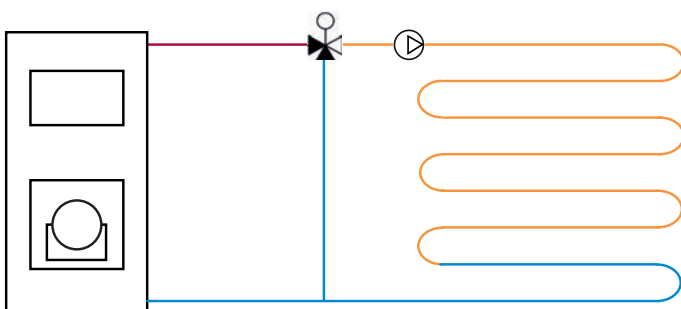

Diverting Valve

LK 551 HydroMix F



- Adjustable diverting temperature



TECHNICAL DATA

Max. working pressure	1.0 MPa (10bar)
Working temperature	Min. 5 °C/Max. 95 °C
Diverting temp.:	Min. 42 °C/Max. 52 °C
Thread standard	G - male thread (M 1")
Media	Water - Glycol mixture max. 50% Ethanol mixture max. 30%
Material, valve body	Brass EN 12165 CW617N, DZR Brass EN 12165 CW625N
Temperature stability	±3 °C

The LK 551 HydroMix F is a 3-way diverting valve.

Once the media reaches chosen temperature it will be redirected to port C. Below chosen temperature it will be redirected to port H.

Arrows on the valve body indicate the direction of the flow.

M = incoming water

C = outgoing hot water

H = outgoing cold water

The valve requires no maintenance but the installation should be checked regularly.

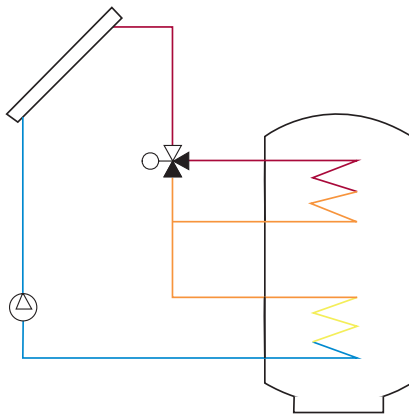

Mixing Valve

LK 552 HydroMix



- Scald protection
- Symmetrical
- Adjustable temperature



TECHNICAL DATA

Max. working pressure	1.0 MPa (10 bar)
Working temperature	Min. 5 °C/Max. 95 °C
Operating temperature	Min. 25 °C/Max. 45 °C Min. 35 °C/Max. 65 °C
Thread standard	Rp - female thread, G - male thread (F 3/4" - 1", M 3/4" - 1 1/4")
Media	Water - Glycol mixture max. 50% Ethanol mixture max. 30%
Material, valve body	Brass EN 12165 CW617N
Temperature stability	±3 °C

LK 552 HydroMix is a mixing valve for water heating and heating systems. The mixing valve has a thermostatic element that regulates the supply of cold as well as hot water in order to achieve the desired temperature. The valve has an anti-scald function that shuts off the incoming hot water flow in case of failure of cold water supply.

Arrows on the valve body indicate the direction of the flow.

C = incoming cold water

H = incoming hot water

M = outgoing mixed water

When fitted on top of boiler/storage tanks with built-in water heaters the valve should be installed with some space between boiler/storage tank and valve so as not to let the function of the valve be affected by heat radiation.

The valve knob is used to set the desired warm water temperature within the specified range. The protective cap prevents unintentional changes of the temperature setting.

The valve requires no maintenance but the installation should be checked regularly.

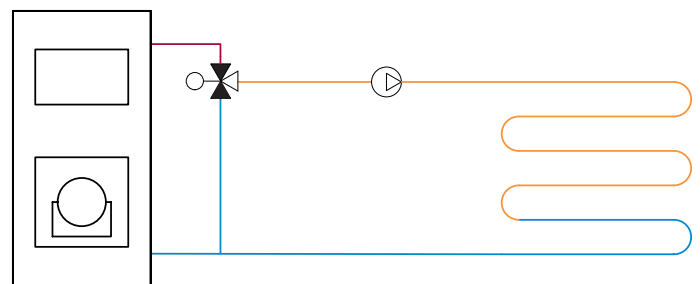
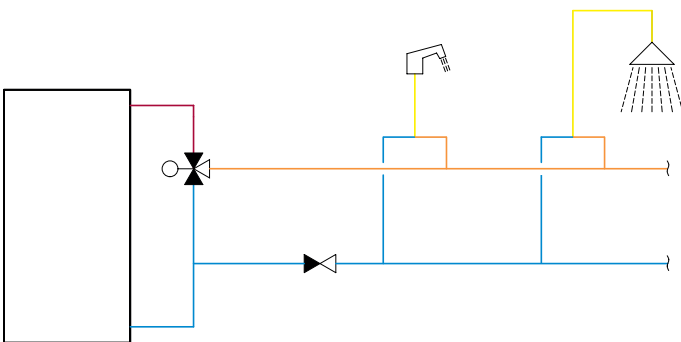

Design your own zone valve



Cable
Molex®
24 VAC
230 VAC

Actuator,
60° angle of rotation

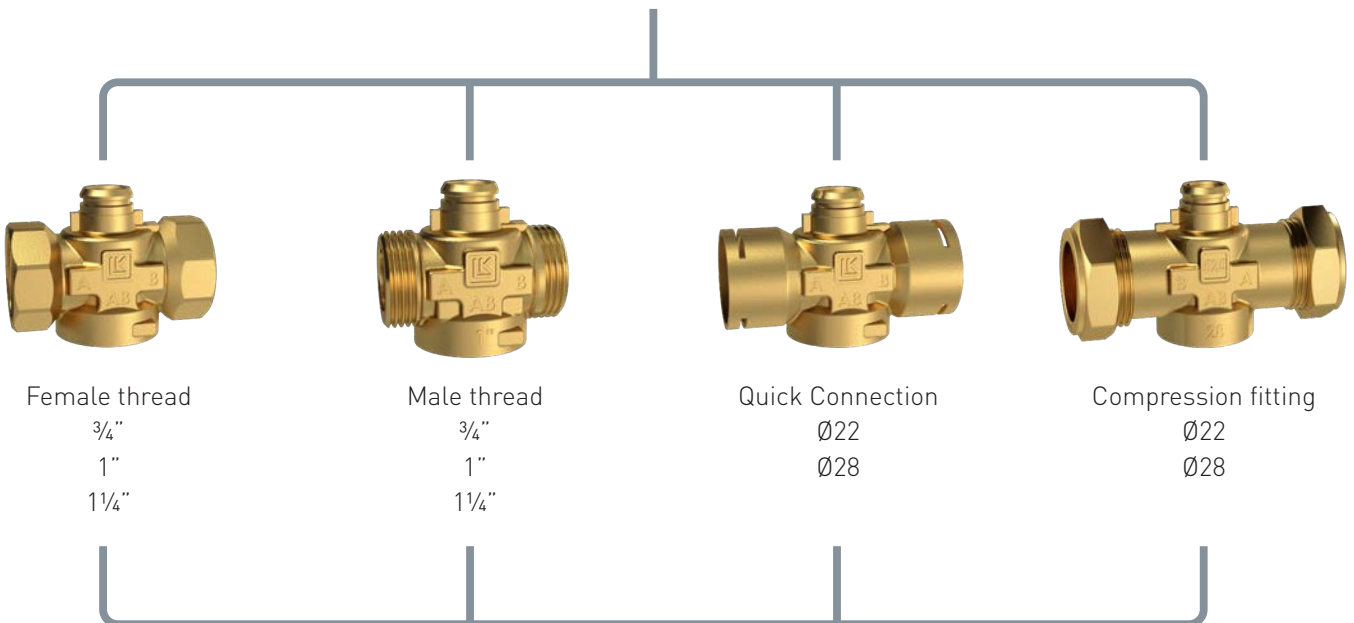

3-Way

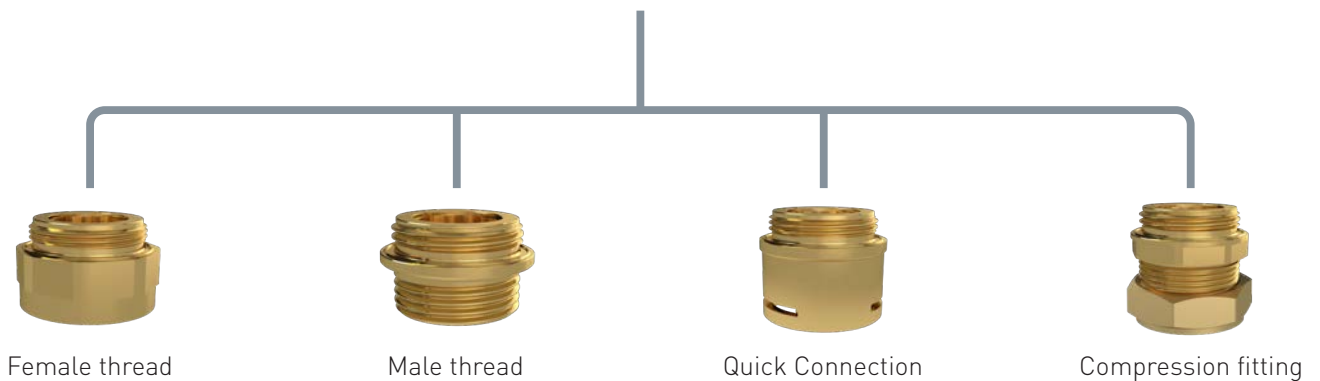

For more information please contact our Sales Department.

Design your own valve



Cable
24 VAC
230 VAC

Actuator,
90° angle of rotation

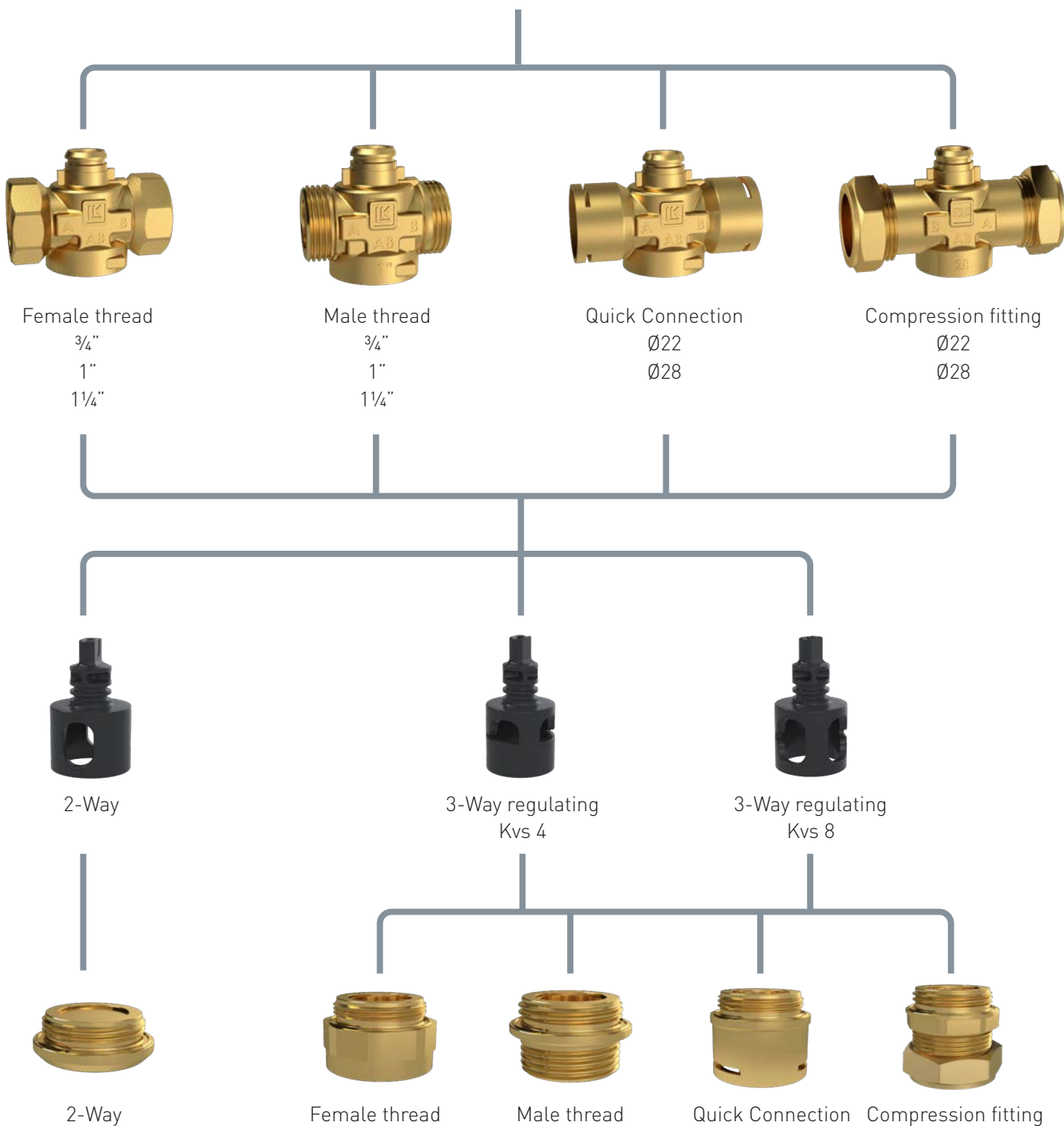

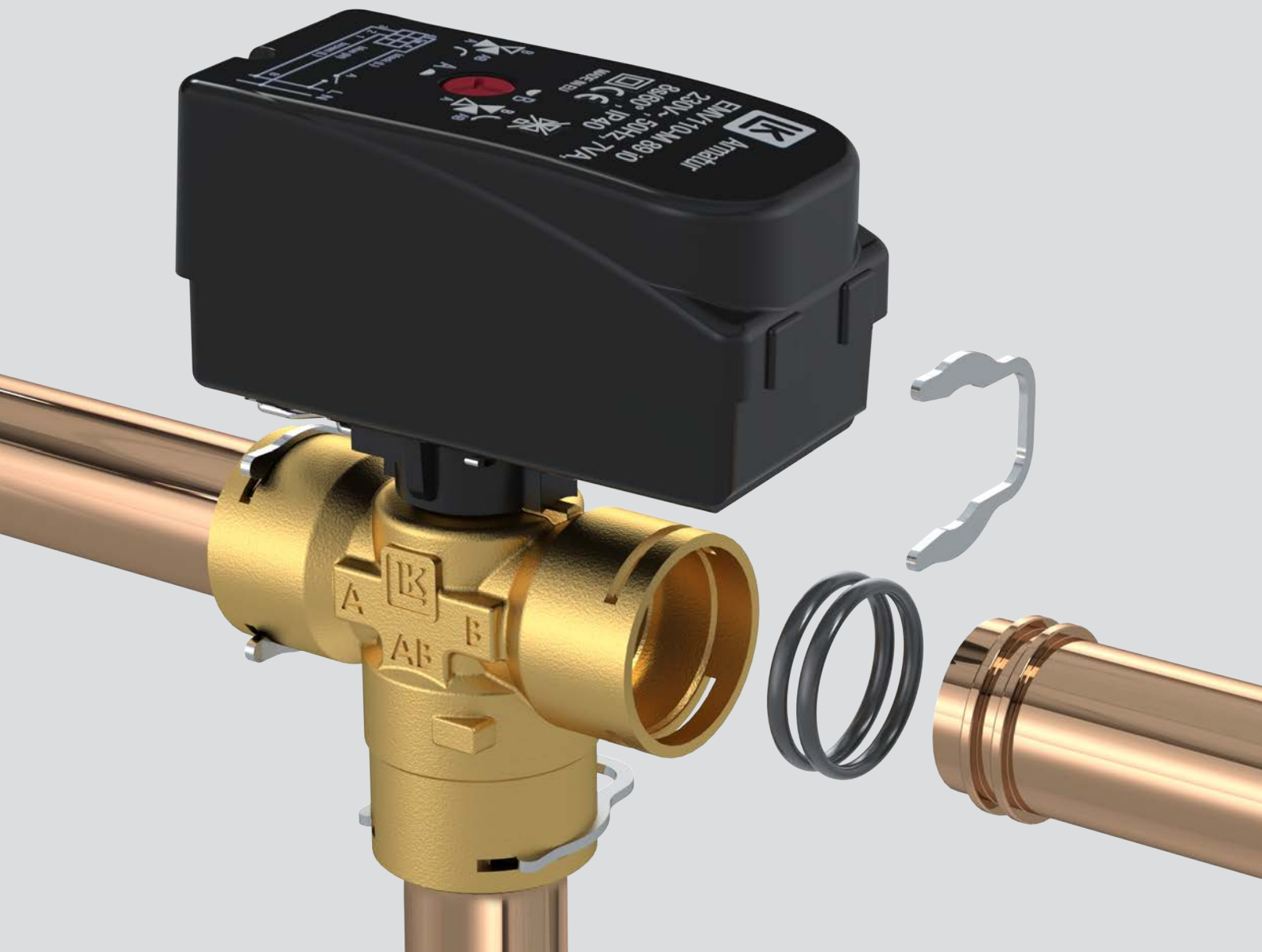

Connect quickly and securely

Quick connection solutions save assembly time and ensure correct installation – every time.

To meet a growing trend for products that can be installed quickly and easily, we have developed a quick-connection solution.

A specially designed end form with two O-rings to seal the joint between the two elements. By using double O-rings, we create a more secure, guaranteed sealed connection. The pipe is held in place in the valve by a locking pin.

End forming can be performed on copper or stainless steel pipes with dimensions \varnothing 22 mm and \varnothing 28 mm

END FORMING FOR DOUBLE O-RINGS TAKES INSTALLATION TO A NEW LEVEL

- Quick installation
- Exactly the same assembly procedure every time
- Allows for any tolerances
- Double O-rings for a guaranteed sealed connection

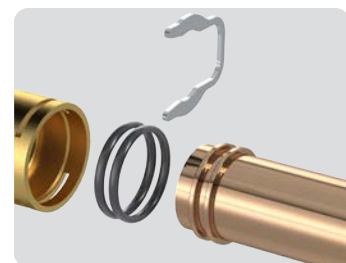

Double O-rings for guaranteed sealed connections that allow for tolerances.

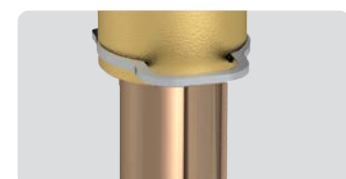

Quick and secure fastening with locking pin

Zone Valves

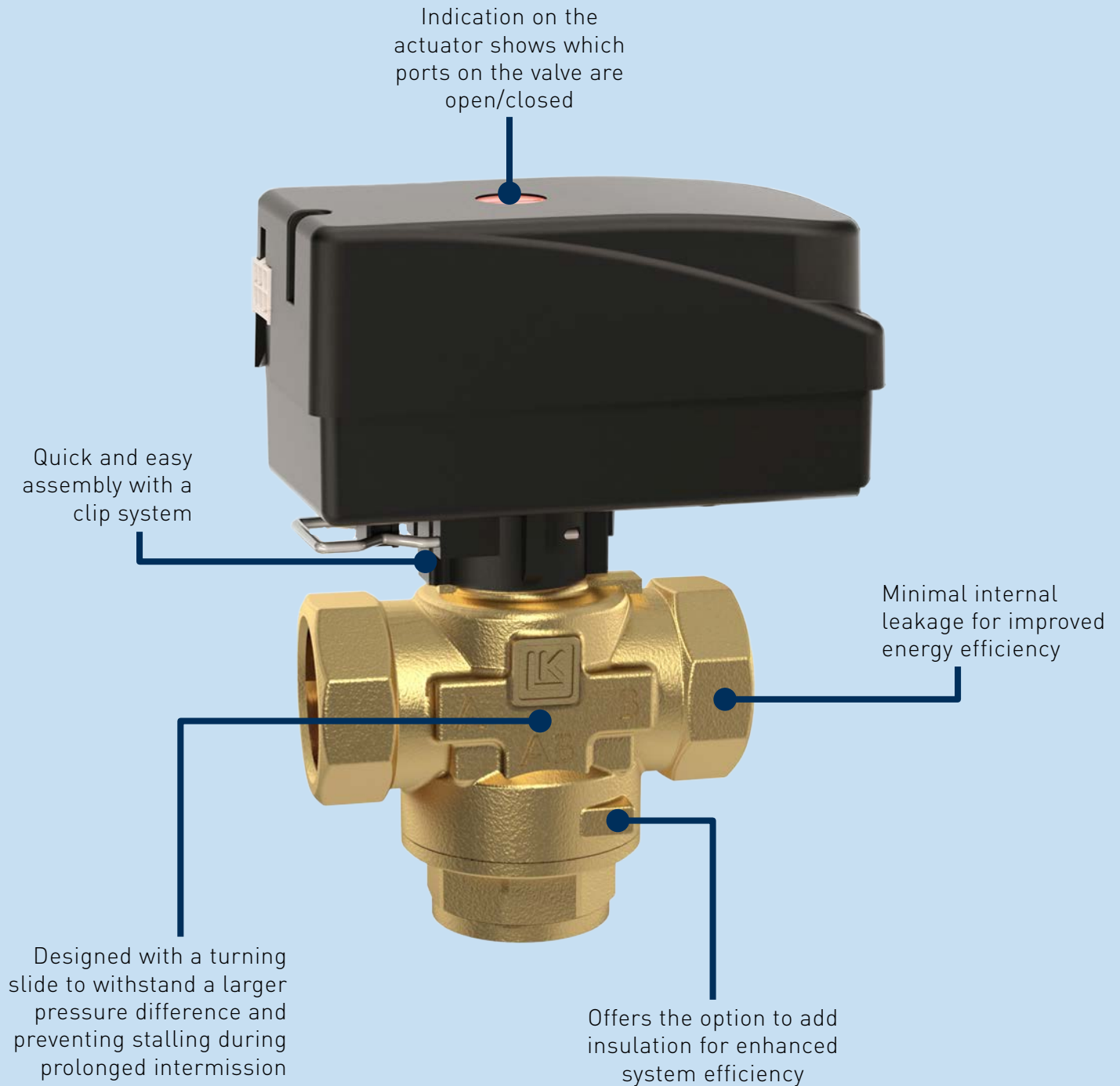

LK 525 MultiZone 3W is a motorized 3-way zone valve with a unique turning slide which allows it to withstand a larger pressure difference and reduces the risk of it stalling after a long intermission. This makes it especially suited for heat pump applications where there can be long intermissions between the changes to the direction of the flow during the warm season. Plus, its minimal internal leakage and quick clip system assembly make it a reliable choice for precise On/Off control.

Zone Valves

LK 525 MultiZone 3W



- Turning slide to reduce risk of stalling
- Minimal internal leakage
- Quick and easy assembly with clip system



TECHNICAL DATA

Angle of rotation	60°/360°
Leakage	< 0.1% of Kvs at 100 kPa Solar: < 0.5% of Kvs at 100 kPa
Operation time	8 seconds (60°)
Max. working pressure	1.0 MPa (10 bar)
Max. differential pressure	100 kPa (1 bar)
Working temperature	Min. 5 °C/Max. 80 °C (90 °C briefly)
Art.no. 066399, 066418:	Min. 5 °C/Max. 70 °C (80 °C briefly)
Cooling/Heating (inkl. adapter):	Min. -15 °C/Max. 120 °C (160 °C briefly)
Ambient temperature	Min. 1 °C/Max. 60 °C
Thread standard	Rp - female thread, G - male thread, ISO 228/1 (F ¾" - 1¼", M ¾" - 1¼", 22, 28 mm)
Protection class	IP 40 (Molex®) / IP 44 (Cable)
Media	Water - Glycol mixture max. 50% Ethanol mixture max. 30%
Electrical connection	Fixed wire alternatively Molex®-compatible connector
Signal connector	Single pole SPST
Cable specification	Dimension 3 x 0.75 mm ²
Wire colours	Blue, brown, black
External insulation	PVC
Connection	Molex® or Molex®-compatible connector, 6-circuit
Actuator	7 VA, 230 VAC, 50 Hz 7 VA, 24 VAC, 50 Hz
Material, valve body	Brass EN 12165 CW617N
Material, external cover	Brass EN 12164 CW614N
Material, slide/spindle	PPS Composite
	Actuator only



LK 525 MultiZone 3W is a motorized 3-way zone valve for On/Off control. The zone valve is designed with a turning slide which allows it to withstand a larger pressure difference and reduces the risk of it stalling after a long intermission. This makes it especially suited for heat pump applications where there can be long intermissions between the changes to the direction of the flow during the warm season. On the upper surface of the actuator is an indicator that shows which port is open.

Installing the 066177 plastic adapter between the valve unit and the motor protects the motor against condensation, icing and high temperatures.

The zone valve must not be installed with the motor underneath the valve unit.

In case of a power failure, the valve cone stays in its current position. When the power is switched off, the valve can be manually set to the centre position, which distributes the flow between the heating and tap water circuits. Remove the motor and turn the spindle about 30° or turn until hot water flows through both valve ports. When the power is restored, turn the valve back to its original position and reinstall the motor.

Please note that the motor can be installed in only one position.

The valve requires no maintenance but the installation should be checked regularly.

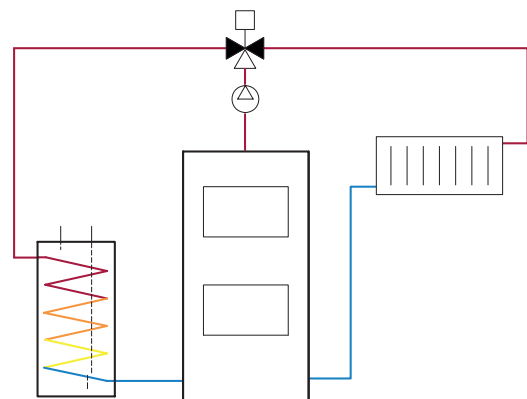
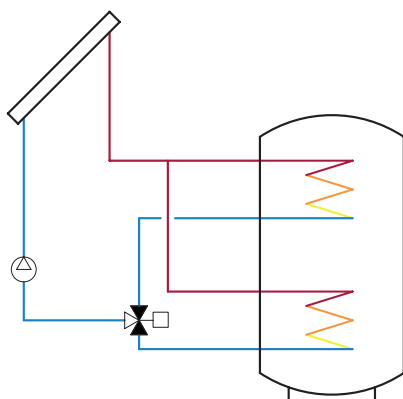

Zone Valves

LK 525 MultiZone 2W



- Simple and flexible assembly with clip system
- Actuators are available as normally closed (NC) or normally open (NO). Direction is displayed on the actuator

TECHNICAL DATA

Angle of rotation	90°/360°
Leakage	< 0.1% of Kvs at 100 kPa
Operation time	12 seconds (90°)
Max. working pressure	1.0 MPa (10 bar)
Max. differential pressure	100 kPa (1 bar)
Working temperature	Min. 5 °C/Max. 80 °C (90 °C briefly)
Ambient temperature	Min. 1 °C/Max. 60 °C
Thread standard	Rp - female thread, G - male thread, ISO 228/1 (F 3/4" - 1 1/4", M 3/4" - 1 1/4", 22, 28 mm)
Protection class	IP 44
Media	Water - Glycol mixture max. 50% Ethanol mixture max. 30%
Electrical connection	Fixed wire
Signal connector	Single pole SPST
Cable specification	Dimension 3 x 0,75 mm ²
Wire colours	Blue, brown, black
External insulation	PVC
Actuator	7 VA, 230 VAC, 50 Hz
Material, valve body	Brass EN 12165 CW617N
Material, external cover	Brass EN 12164 CW614N
Material, slide/spindle	PPS Composite
CE	Actuator only

LK 525 MultiZone is a motorized 2-way zone valve for application in heating systems in which the flow through one or more zones is to be controlled. The zone valve has On/Off control and is designed with a turning slide which allows it to withstand a larger pressure difference and reduces the risk of it stalling after a long intermission. On the upper surface of the actuator is an indicator that shows which port is open or closed.

The zone valve must not be installed with the motor underneath the valve unit.

In case of a power failure, the valve cone stays in its current position. When the power is switched off, the valve can be manually set. Remove the motor and turn the spindle to your selected position. When the power is restored, turn the valve back to its original position and reinstall the motor.

Please note that the motor can be installed in only one position.

The valve requires no maintenance but the installation should be checked regularly.

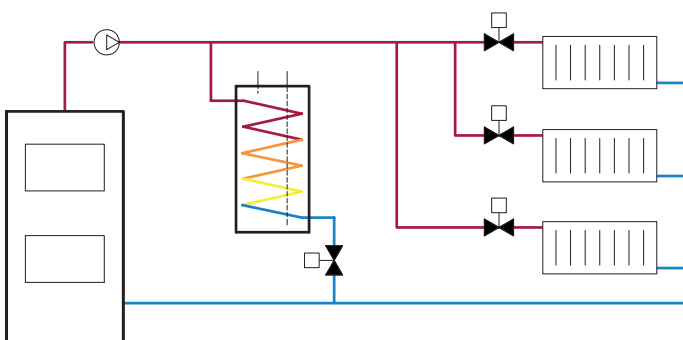

Temperature Controllers

Booster function for rapid indoor temperature adjustments

Nine built-in programs for energy optimization

Holiday and timer settings for convenient and energy-saving control

Available in two versions; with fixed cable SmartComfort RT or wireless receiver SmartComfort RTW

Automatically adapts to mixing valve direction for easy installation

Maintains settings during power outages

LED display shows current status and selected value

See current status of supply temperature, min. temperature, max. temperature, curve setting, and outdoor temperature



Elevate your indoor comfort with **LK 130 SmartComfort**. This intelligent controller offers precise temperature adjustments and integrates easily with existing systems. The included room temperature unit enhances control with preset programs and outdoor temperature monitoring. For top efficiency, connect SmartComfort PC to manage the circulating pump and prevent stalling.

Temperature Controllers

LK SmartComfort



- Adjustments are easily made with push buttons
- Wired or wireless room controllers available
- The same actuator for SmartComfort 110, 120 and 130 enabling easy upgrading

TECHNICAL DATA

Power consumption	< 3 VA
Primary voltage, adapter	100-240 VAC, 50/60 Hz
Secondary voltage, adapter	24 VDC
Angle of rotation	90°
Torque	5 Nm
Ambient temperature	Actuator: Min. 0 °C/Max. 50 °C (in operation) Room Temperature Unit: Min. 0 °C/Max. 40 °C
Min. supply temperature	LK 110/120/130: 5 - 40 °C
Max. supply temperature	LK 110/120/130: 20 - 99 °C
Control range	LK 100 CT: 5 - 99 °C, LK 110, 120, 130: Min. 5 °C/Max. 35 °C
Curve slope	LK 110/130: 1.0 - 9.9
Parallel displacement	LK 110/130: ± 10 °C
Protection class	Actuator: IP 40 Room Temperature Unit: IP 20



LK SmartComfort is an electronic controller that has an automatic choice of direction to adapt to the direction of the mixing valve. LED-indicators show if the controller is opening or closing the valve. The supply temperature can be limited with a minimum and a maximum value. LED-indicators show if the controller is opening or closing the valve. Adjustments are easily made with the push buttons marked "+" and "-". The selected value will be shown on the LED-display.

LK SmartComfort is easy to install onto new as well as existing mixing valves. Mounting kits for installation onto mixing valves of other brands are available - see separate page.

The plug-in adapter provides quick and easy do-it-yourself installation. In case of a power outage the controller will keep its settings and the actuator will stop in its current position. By disengaging the controller, the mixing valve can be manually operated.

LK 100 CT - CONSTANT TEMPERATURE CONTROLLER

LK 100 SmartComfort CT is an electronic temperature controller designed to keep the supply temperature in underfloor heating systems or the return temperature to solid fuel boilers at a constant level. The flow temperature is adjustable between 5 - 99 °C.

LK 100 CT - ITEMS INCLUDED

- Temperature controller
- Adapter 24 VDC
- Mounting kit for mixing valve
- Supply temperature sensor with 1 m cable



LK 100 SMARTCOMFORT CT

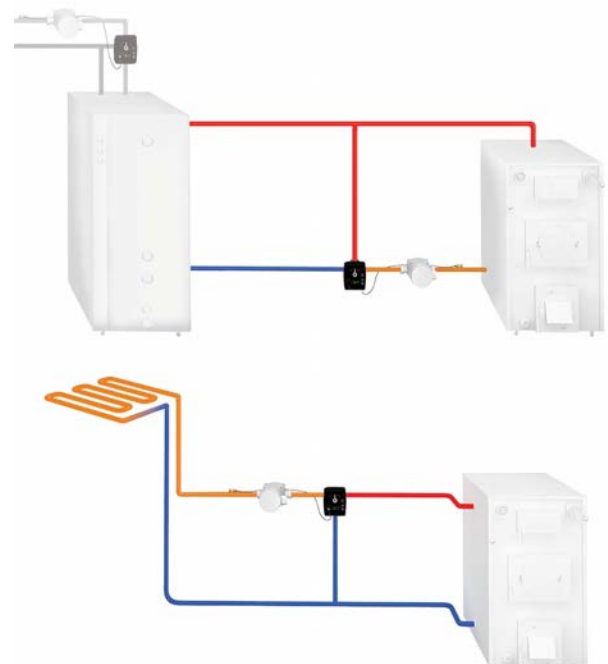

LK 110 - WEATHER COMPENSATED TEMPERATURE CONTROLLER

LK 110 SmartComfort is an electronic weather compensated temperature controller for hydronic radiator and underfloor heating systems. By measuring the supply and outdoor temperatures LK 110 SmartComfort regulates the mixing valve to provide the system with the exact amount of heat required in the building at any given time. The supply temperature can be limited with a minimum and a maximum value. The current supply and outdoor temperatures can be read on the controller display.

LK 110 - ITEMS INCLUDED

- Temperature controller
- Adapter 24 VDC
- Mounting kit for mixing valve
- Supply temperature sensor with 1 m cable
- Outdoor temperature sensor with 15 m cable and protective casing



LK 110 SMARTCOMFORT

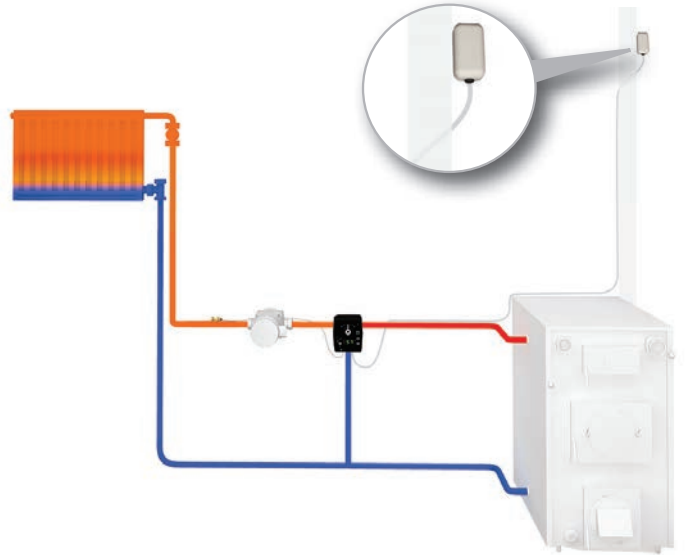

LK 120 - INDOOR TEMPERATURE CONTROLLER

LK 120 SmartComfort is an electronic indoor temperature controller for hydronic radiator and underfloor heating systems. By measuring the supply and indoor temperatures LK 120 SmartComfort regulates the mixing valve to provide the system with the exact amount of heat required in the building at any given time. The supply temperature can be limited with a minimum and a maximum value.

LK 120 SmartComfort is delivered with a room temperature unit allowing easy setting of the desired indoor temperature.

LK 120 - ITEMS INCLUDED

- Temperature controller
- Adapter 24 VDC
- Mounting kit for mixing valve
- Supply temperature sensor with 1 m cable
- Room temperature unit SmartComfort RT with 15 m cable or Room temperature unit SmartComfort RTW with wireless receiver



LK 120 SMARTCOMFORT

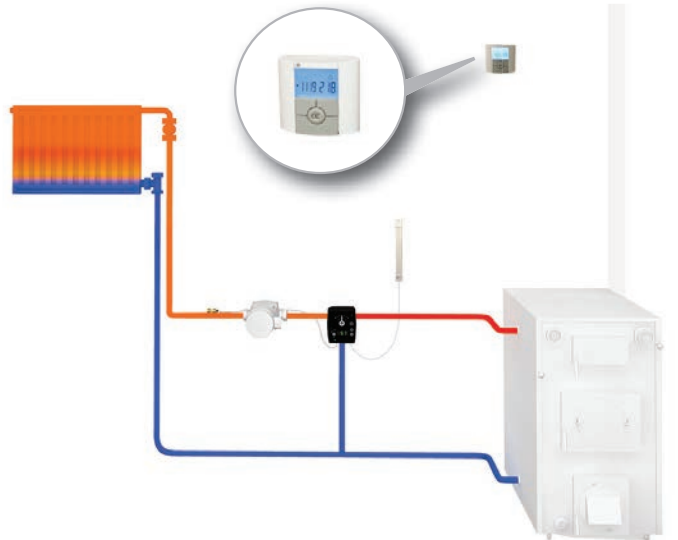

LK 130 - WEATHER COMPENSATED INDOOR TEMPERATURE CONTROLLER

LK 130 SmartComfort is an electronic, weather compensated, indoor temperature controller for hydronic radiator and underfloor heating systems. By measuring the supply, outdoor and indoor temperatures LK 130 SmartComfort regulates the mixing valve to provide the system with the exact amount of heat required in the building at any given time. The supply temperature can be limited with a minimum and a maximum value. LK 130 SmartComfort is delivered with a room temperature unit allowing easy setting of the desired indoor temperature.

LK 130 - ITEMS INCLUDED

- Temperature controller
- Adapter 24 VDC
- Mounting kit for mixing valve
- Supply temperature sensor with 1 m cable
- Outdoor temperature sensor with 15 m cable and protective casing
- Room temperature unit SmartComfort RT with 15 m cable or Room temperature unit SmartComfort RTW with wireless receiver



LK 130 SMARTCOMFORT

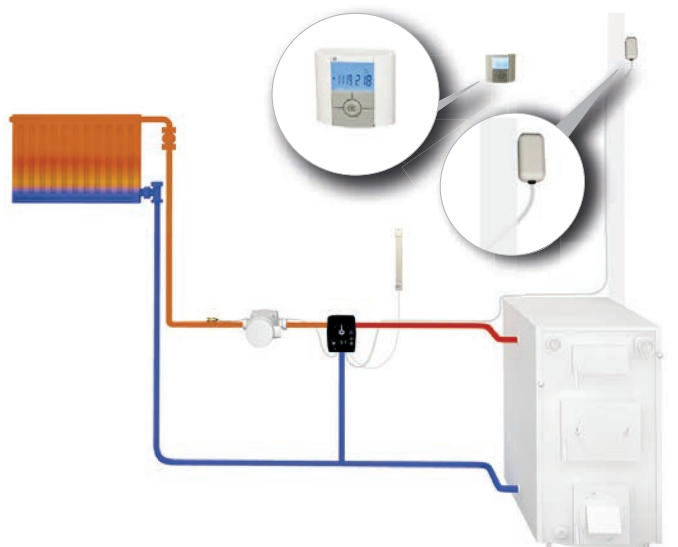

PUMP CONTROL - SmartComfort PC

For further energy saving a pump control, SmartComfort PC, can easily be connected to the controller - see under Accessories. SmartComfort PC stops the circulating pump when no heat is required and exercises pump every two days, thus eliminating the risk of pump stalling after an intermission.

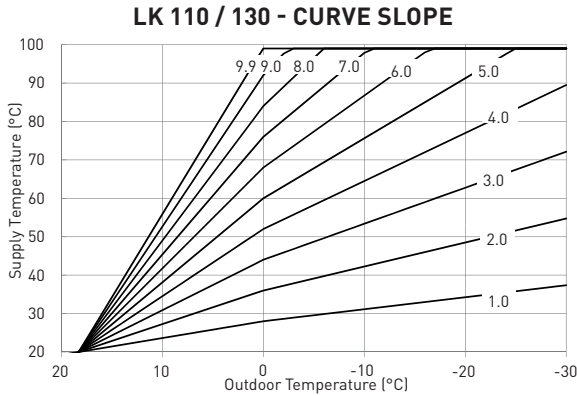

Dependent on the dimension of the heating system and the insulation of the building, the heating curve may need to be adjusted in order to achieve the desired room temperature. The curve slope and the parallel displacement are easily adjusted with the push buttons.

LK 120/130 DISPLAY - ROOM TEMPERATURE UNIT

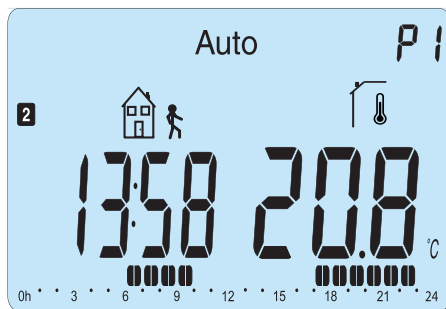

LK ROOM TEMPERATURE UNIT

The room temperature unit is available in two versions; with fixed cable SmartComfort RT or wireless receiver SmartComfort RTW.

The room temperature unit is equipped with a connection port for external control, such as via a GSM modem, making it possible to activate a preset temperature change via mobile phone.

For further energy saving and increased comfort there are nine preset programs with scheduled temperature changes. You can also create your own programs. Additional functions such as holiday and timer settings are available. The current outdoor temperature can be read on the room temperature unit.

After a temperature setback the room temperature unit applies a booster function which briefly increases the supply temperature in order to quickly reach the desired room temperature. Should the room temperature unit sense a sudden change in temperature, such as when airing a room, the unit disregards this change for the following half hour.

LK 130 SMARTCOMFORT

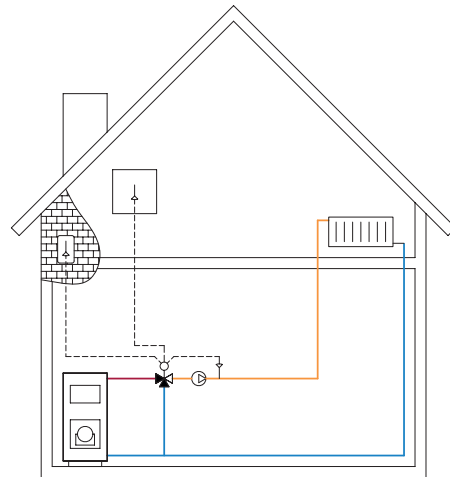

Safety Valve

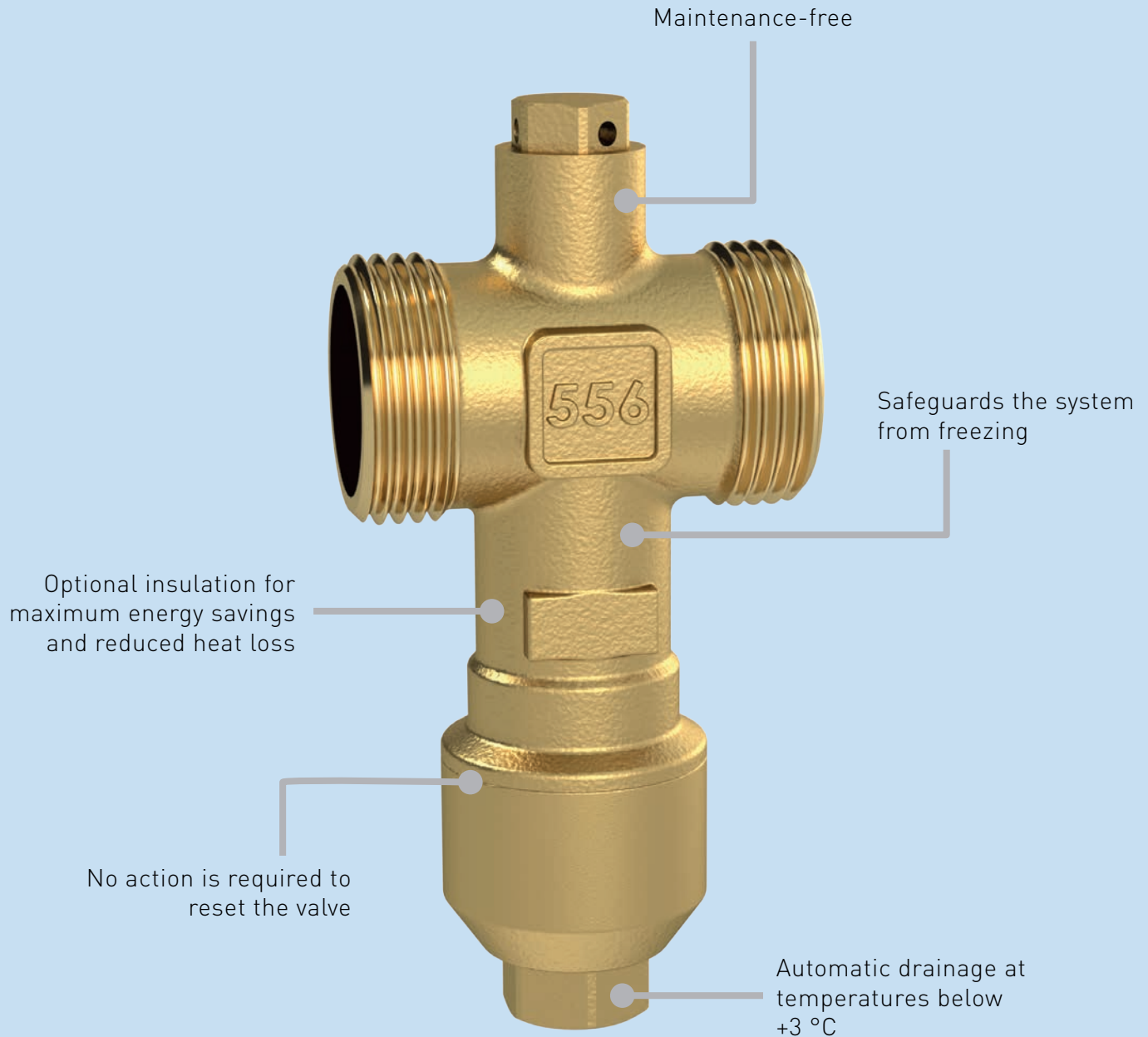

Protect your heating system from freezing with the **LK 556 AntiFreeze**. Designed for air/water heat pumps, it automatically drains the system if temperatures dip below +3°C, ensuring your heating system remains safe and operational. Boost energy efficiency with available insulation, and enjoy the benefits of a maintenance-free valve.

Safety Valve

LK 556 AntiFreeze



- Protects heating system from freeze damage
- The valve is maintenance-free
- Can be insulated to save energy



TECHNICAL DATA

Max. working pressure	0.6 MPa (6 bar)
Working temperature	0-75 °C
Opening temperature	3 °C
Ambient temperature	-30-60 °C
Storage temperature	-30-60 °C
Thread standard	G - male thread (M 1" - 1 1/4")
Media	Water
Material, valve body	Brass EN 12165 CW617N
Material, sealing	EPDM

LK 556 AntiFreeze protects your heating system, usually in an air/water heat pump, if the fluid temperature should drop below +3°C by draining the system. This prevents the heating system from freezing.

If the valve opens and drains the system, no action is required to reset the valve, the system can be refilled again as soon as normal circulation in the heating system is resumed.

Insulation is available as an accessory for maximum energy saving. Refer to Accessories & Spare parts.

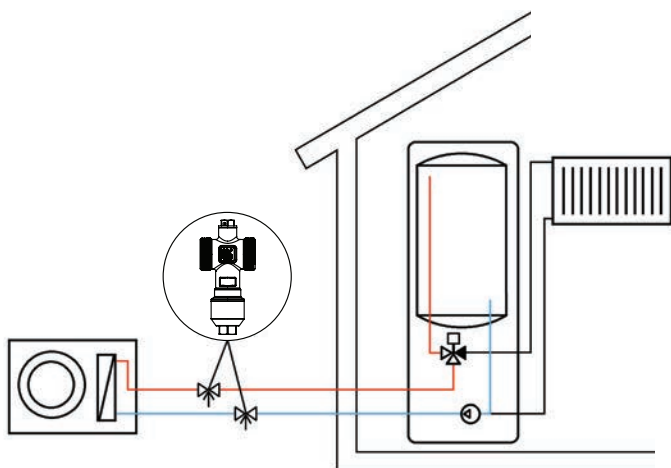

Valve combination

LK 322 CoolUnit



- Insulation against condensation
- Energy effective way for free cooling
- Recharge the borehole during the summer



TECHNICAL DATA

Max. working pressure	0,6 MPa (6 bar)
Working temperature	Min. -20 °C/Max. 80 °C
Thread standard	G - male thread (M 1"-1¼")
Media	Water - Glycol mixture max. 50%
Material, valve body	Brass EN 12165 CW617N
Material, sealing	EPDM

The LK 322 CoolUnit is a valve combination that utilises the cold available in a system with a geothermal heat pump.

By running the refrigerant fluid in the collector hose to a fan coil, you can cool your home with the cold naturally found in the ground. In addition, the borehole is recharged during the summer, which increases the performance of the heat pump.

The LK 322 CoolUnit also contains a non-return valve to ensure the liquid is run in the right direction when fitting the shunt group with its own circulation pump. See LK HydronicGroup 90C for a suitable shunt group.

The LK 322 have two 1" male thread for connection to the collector pipe. Two ball valves with 3/4" male thread for connection to convector pipe.

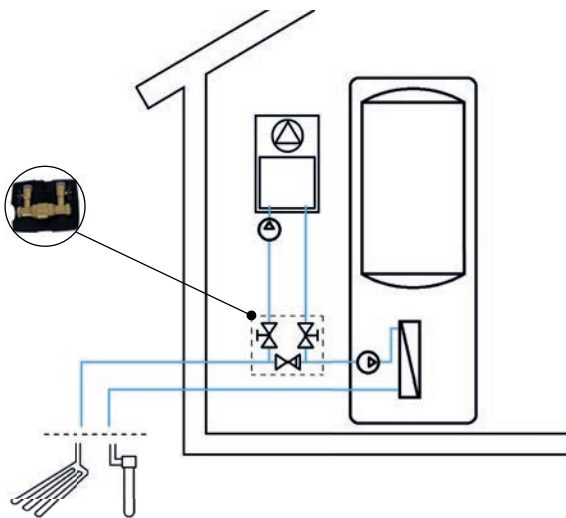

Cyclone filter

LK 360 NetMag



- Extend the service life of your heating system
- Energy-saving
- Rotatable filter housing, can be installed vertically and horizontally



TECHNICAL DATA

Max. working pressure	0.4 MPa (4 bar)
Working temperature	0-90 °C
Thread standard	G - female thread, ISO 228/1 (F 3/4" - 1 1/4")
Media	Water - Glycol mixture max. 30%
Material, valve body	Nickel-plated Brass EN 12165 CW617N
Filter housing	Polyamide PA66
Ball valve	Nickle-plated brass CW617N
Magnet	Neodymium 11,000 gauss

The LK 360 NetMag is a magnetic cyclone filter that effectively protects your boiler and other components in your heating system by collect dirt and magnetite.

LK 360 shall be installed on the return pipe at the boiler inlet to protect the boiler from contamination. The filter housing is rotatable and can be installed vertically or horizontally, making it suitable for most spaces.

PRESSURE DROP DIAGRAM

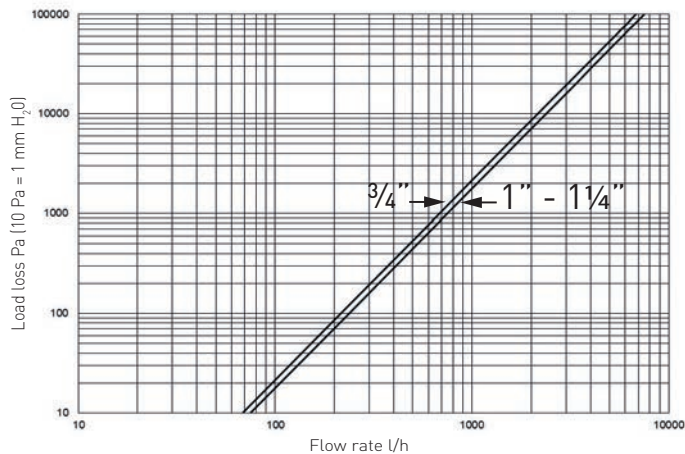

Curious about other products?

Product Catalogue



Product Catalogue 2024

You will find our new product catalog for 2024 quickly and easily, in several languages, via the QR code below!



Filling Valves



LK 321 MultiFill® Solar

- Compact design
- Quick installation



LK 521 MultiFill®

- For geothermal heat pumps
- Compact design
- Insulation protects against condensation and icing
- Minimal pressure drop due to the placement of the filter in the ball



Safety Group



LK 994 SafetyGroup

- Adjustable bracket
- Automatically closes against the heating system when removing expansion vessel



Safety Relief Valve



LK 519 ThermoSafe

- Protect your boiler against overpressure
- Protective flexible hose for capillary tube



Diverting / Zone Valve



LK 525 MultiZone 3R

- Low internal leakage
- The slide is designed to provide accurate regulation at low flows
- Click system for actuator



Filter Ball Valves



LK 522 FilterBall
LK 522 FilterBall Magnet

- DZR Brass
- Easy to clean the filter



Loading Units



LK 810 ThermoMat 2.0 G
LK 811 ThermoMat 2.0 W

- Compact design
- Adjustable return temperature (LK 811)
- Electronic regulation ensures an easy operation (LK 811)



Mixing Valves



LK 840 HG ThermoMix® 2.0
LK 850 HG ThermoMix® 2.0

- Easy to adapt for electronic controller
- Suitable for pump groups



Valve Actuator



LK 950 Valve Actuator

- Up to 10 Nm
- Wide range of products



Thermic Valves



LK 823 ThermoVar® R

- Increases system efficiency
- Prevents condensation and tarring
- Adjustable temperature



Prefabrication

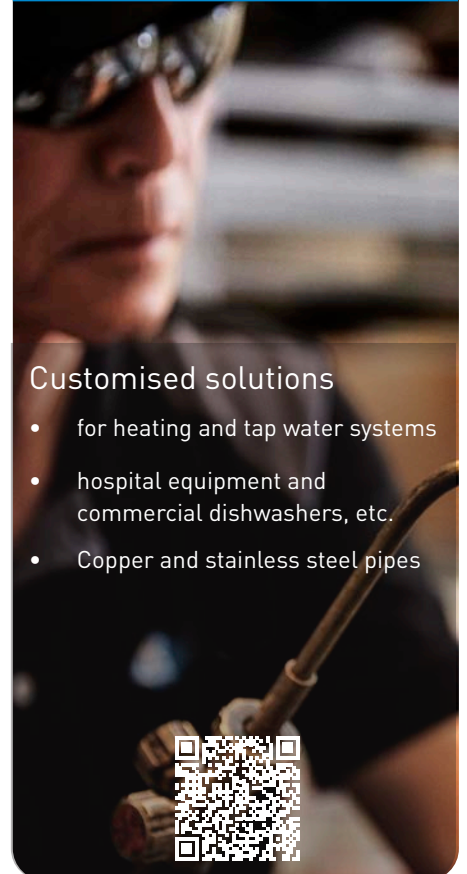

Customised solutions

- for heating and tap water systems
- hospital equipment and commercial dishwashers, etc.
- Copper and stainless steel pipes





Follow us on social media

Keep up to date with all the news from LK Armatur. We'll pass on all the latest news, upcoming events, job vacancies and much more.

So follow us to keep up to date with what we're doing!



Facebook



Instagram



LinkedIn



YouTube

Table of Contents

COMPANY INFORMATION.....3

LK ARMATUR.....	4
Table of Contents	5

APPLICATIONS

Products for Waterheating	6
Products for Heat Pumps	6
Products for Biofuel.....	7
Products for Underfloor Heating.....	7
Products for Solar Heating.....	8
Products for District Heating.....	8

PUMPGROUPS.....9

LK HydronicGroup 90C.....	12
LK HydronicGroup C/C 90.....	13
LK HydronicGroup C/C 125.....	14

TAP WATER UNITS16

LK 250 TapWaterUnit	17
---------------------------	----

SOLAR PUMP UNITS18

LK 211 SolarStation (single)	19
LK 212 SolarStation	20

ELECTRIC PORTABLE BOILERS21

LK 450 EasyHeat P.....	22
LK 450 EasyHeat M.....	23

VALVES FOR WATER HEATING24

LK 551 HydroKit HWC	25
LK 551 HydroKit Solar.....	26
LK 551 HydroMix.....	27
LK 551 HydroMix F.....	28
LK 552 HydroMix.....	29

ZONE VALVES

Design your own zone valve.....	30
Connect quickly and securely	32
Zone Valves	33
LK 525 MultiZone 3W.....	34
LK 525 MultiZone 2W.....	35

TEMPERATURE CONTROLLERS36

LK SmartComfort	37
-----------------------	----

OTHER PRODUCTS

Safety Valve	40
LK 556 AntiFreeze	41
LK 322 CoolUnit.....	42
LK 360 NetMag.....	43

Curious about other products?.....44

Follow us on social media46

LK ARMATUR AB

Garnisonsgatan 49
SE-254 66 Helsingborg
Sweden

Phone: +46 (0)42-16 92 00
info@lkarmatur.se
order@lkarmatur.se

FOR THE SIMPLER, SMARTER EVERYDAY

Simpler. Smarter. More sustainable. At LK, we believe there's a better way to do everything. It's a belief all of us at LK apply to every product and solution we create – from water, heating and hydronic solutions to pipe extrusion.

LK Armatur is a leader in Europe, producing millions of valves per year for the global HVAC market. Beyond individual products, we understand how all parts interact in your complete application. From standard to sophisticated customizations of valves, controllers, components and prefabricated units, our full-spectrum expertise makes it easy to get the results you need today, while anticipating your needs tomorrow.

